

# 2014 Annual Report

Pushing Forward for Industry Competitiveness



**MIRDC**

Molding the Future of Metal Industries



# TABLE of CONTENTS

Message from the DOST Secretary .....	2
Message from the OIC - MIRDC .....	3
Vision, Mission and Core Values .....	4
QEMS Policy.....	5
Research and Development.....	6
Technology Transfer.....	32
S&T Services.....	48
Support Services.....	52
Resource Management .....	60
Financial Resource Management.....	70
Management Staff.....	72
Governing Council.....	74
Location Map and Extension Offices .....	76
Organizational Structure .....	77
MIRDC Hymn.....	78
Editorial Board.....	79

# MESSAGE FROM THE DOST SECRETARY

The Department of Science and Technology strongly promotes science, technology, and innovation as tools that will shape us into becoming a more productive and globally competitive nation. The DOST, with all its attached agencies, is focused on building technological self-reliance through the stringent harnessing of research and development capabilities.



As the implementation of our projects unfolds, we see convergence of all our efforts. In 2014, the realization of the DOST's Eight Outcomes deliverables was made possible through the hard work and unique expertise of each of the attached agencies. The Metals Industry Research and Development Center has, once again, demonstrated its commitment to contribute to the achievement of our goals.

The MIRDC Annual Report for 2014 tells about the journey towards the achievement of our vision for the country. Let this journey inspire others so that all of us will constantly be reminded of our potential in overcoming the challenges posted to us during these trying times.

Together with our partners, the MIRDC has successfully completed projects focused on addressing national concerns. We are counting on being able to provide more S&T-based and technology-driven solutions for the growth of the metals and engineering industries, and the stability of the country's economy.

Congratulations to the MIRDC for all its accomplishments in 2014. Your determination and strong desire to serve the M&E industries are definitely an inspiration to strengthen our efforts in science, technology, and innovation to improve the lives of the Filipino people.

Mabuhay!

  
**MARIO G. MONTEJO**  
*Secretary, DOST  
and Chairperson, MIRDC Governing  
Council*

# MESSAGE FROM THE OIC - MIRDC

True to our mission, the Metals Industry Research and Development Center engages in projects and activities that aim to address the metals and engineering industries' need for training, information exchange, quality control and testing, research and development, and business economics and advisory services. The Center performed all these activities in 2014, and has even surpassed some of its targets. Indeed it has been an eventful year for the MIRDC.

A bird's eye view of the year 2014 is studded with a number of our proud accomplishments. We were unrelenting in our efforts to achieve the objectives of our advanced transportation projects. We are continuously making progress in the development of food processing equipment, as well as the hand tractor-attached agricultural implements. We remain involved in projects related to machine-building, capability building, surface engineering and disaster mitigation.

We launched the Die and Mold Solution Center (DMSC), which is the first of its kind facility in the country. The DMSC is one of the MIRDC's way of supporting the tool, die and mold making industry by providing them access to modern equipment and technologies, as well as modules and programs for manpower development.

The Automatic Trash Rake (ATR) was also launched this year. The ATR project did not only serve as a platform for the MIRDC to demonstrate a home-grown engineering solution to one major problem of Metro Manila, it also led to the creation of a partnership with the Quezon City LGU.

We have jump-started initiatives relative to the establishment of a Gear Making and Assembly Facility at the MIRDC. We are bent on providing this much needed technol-

ogy to address a foremost need of the M&E industries especially in the transportation, metalworking, and agro-industrial sectors.

On top of all these high-impact projects, we had our hands full with the usual responsibilities and deliverables in 2014. I commend all divisions that make up the MIRDC. Behind all the achievements of the Center are the efficient and effective employees who work together, learn from each other, and share the fulfillment of giving their best in the pursuit of excellence.

I am proud to present to you the MIRDC's 2014 Annual Report: Pushing Forward for Industry Competitiveness. All of the Center's initiatives are directed toward strengthening capabilities and making our M&E industries at par with those of other countries around the world. As a science nation, let us build up and maximize our gains from our distinct expertise. Further, let us keep the faith and always believe that our local technologies work. For wherever this global competition takes us, our local M&E industries can make it.



**ROBERT O. DIZON**  
*Assistant Secretary, DOST  
and Officer-in-Charge, MIRDC*



# VISION

An internationally recognized institution providing research and development, technology transfer, and scientific and technological services supporting the growth and global competitiveness of the metals, engineering, and allied industries.

# MISSION

To provide both government and private sectors in the metals and engineering industry with professional management and technical expertise on the training of engineers and technicians; information exchange; trade accreditation services; quality control and testing of metal products; research and development; and business economics advisory services.

# CORE VALUES

## *eM*powerment

- We get the job done and make things happen.
- We derive our collective success from individual strengths and capabilities.

## *I*ntegrity

- We do what is right even when no one is looking.
- We act responsively, work honestly, and encourage transparency.

## *R*espect

- We demonstrate justness and fairness in all we do.
- We value diversity and view another person as an individual of fundamental worth.

## *D*ynamism

- We perform our jobs with vigor and enthusiasm.
- We welcome change as an opportunity for growth and continual improvement.

## *C*ommitment

- We are passionate at what we do.
- We dedicate ourselves to the achievement of our vision, mission and goals.

# QUALITY & ENVIRONMENTAL POLICY

We are committed to provide products and services to both the government and the private sectors in the metals and engineering and allied industries with the highest standards of quality and reliability within our capabilities and resources and to continually improve the effectiveness of our Quality and Environmental Management Systems at all times in order to meet customer satisfaction.

We shall manage and control our activities in order to minimize adverse impacts on the environment, prevent pollution and safeguard the health and safety of all employees, stakeholders, customers, suppliers and the surrounding community.

To fulfill these commitments, we shall:

- Adopt new and appropriate technologies and processes to continually improve the quality of our products and services and our environmental performance;
- Implement programs to enhance the competency and awareness of all personnel;
- Promote quality and environmental awareness and health and safety practices in all levels of the Center;
- Comply with all applicable laws and regulations in the country including the requirements of DOST, customers, stakeholders, industry in which we subscribe to;
- Reduce dependence on the use of toxic and hazardous substances, including Ozone Depleting Substance (ODS);
- Implement an effective waste management and waste reduction program including where practicable, recycling and reusing of wastes; and
- Optimize the use of resources by continually identifying, implementing and reviewing practical measures to reduce resources usage.

**R**esearch and development activities of the Prototyping Division fuel the science, technology, and innovation-focused initiatives of the Metals Industry Research and Development Center. The PD's full support to the DOST's vision of attaining technological self-reliance served as the driving force behind the Division's fruitful 2014. This year saw the creation of new partnerships, establishment of state-of-the-art facilities, acquisition of modern equipment, and availment of foreign training of PD engineers, technicians and staff as part of the implementation of high-impact projects.

The PD engaged in projects that are envisioned to cater to the needs of various industries, including food, agriculture, transportation, and manufacturing, to name a few. Benefits will trickle down to the simplest of our fellow Filipinos, and growth is perceived to be felt by sectors that contribute greatly to the country's economic progress. All these positive outcomes are driven by the PD's commitment to create impact to the metals and engineering industries.

## IMPROVEMENT OF THE CNC ROUTER BY ADDING AN AUTOMATIC TOOL CHANGER



Another project under the Advancement in Machine Building Capability is the integration of an Automatic Tool Changer (ATC) to the existing CNC Router. The existing CNC Router utilizes manual tool change operations where the CNC operator needs to calibrate and manually replace the tool for each operation. With the ATC, the cycle time of tool-change operations is shortened, thus, improving the machine productivity. It allows complete machining where different toolings are required for various operations like cutting, engraving, and milling. Moreover, the ATC also ensures the safety of users during tool change operations.

The ATC incorporates an 8-position, straight linear-type tool holder. The tool holder will make the CNC router adaptable and flexible to different routing operations. It also uses a pneumatic elec-

tro spindle replacing the installed conventional spindle.

This project entitled, "Development of an Automatic Tool Changer (ATC) System for the 3-axis Computer Numerically Controlled (CNC) Router Machine," along with the results of the "Optimization of Machine Process Parameters through 2D Image Layout Enhancing and ArtCAM Post-Processing for 3D Machining" project was presented by the MIRDC team in the 7<sup>th</sup> IEEE International Conference on Humanoid, Nanotechnology, Information Technology, Communication and Control, Environment, and Management (HNITCEM) at Puerto Princesa City, Palawan on 12-16 November 2014. These papers were also published in the IEEE digital Xplore library.



## ESTABLISHMENT OF COMPLEMENTARY BABY FOOD PRODUCTION PLANT

The MIRDC, the Food and Nutrition Research Institute, the DOST-National Capital Region, and cooperating Local Government Units initiated the development of a Complementary Baby Food Production Plant in the Philippines, whose main goal is to encourage the local government to adopt DOST-made technologies and utilize them in programs that will enhance the quality of life and well-being of their community, and address pressing issues particularly malnutrition. The setting up of a fully automated production plant to process baby food more efficiently requires a production line that employs a set of sequential operations to refine raw materials and produce a safe and high quality consumable product. Efficiency lies in the effective layouting of plant designed to optimize production line and comply with Good Manufacturing Practices (GMP).

The production line includes eight (8) food processing equipment, namely: a) Rice Pulverizer; b) Mongo Pulverizer; c) Mixer/Blender; d) Twin Screw Extruder; e) Three-Layer Conveyorized Dryer; f) Pulverizer; and g) two (2) units of Powder Packaging Machine. An integrated set-up is envisioned to automatically operate the plant minimizing manpower use. The functional testing of the equipment was conducted on 17 December 2014. Results have shown that the production line achieved the required capacity in producing the Rice-Mongo Instant Baby Food Blend.

The MIRDC is eyeing a local government unit as possible adopter of the technology. Further tests are being conducted at the MIRDC to ensure the efficiency of the technology.



Mongo Pulverizer



Powder Packaging Machine

## DESIGN AND FABRICATION OF EQUIPMENT FOR THE PRODUCTION OF LOCAL CACAO AND COCOA INDUSTRY

The MIRDC, in partnership with the Industrial Technology Development Institute (ITDI), has developed two sets of cacao processing equipment or a total of 11 units of different machines in support to the local cacao industry.

On its second year, the project has produced seven units of cacao processing equipment for the production of cocoa liquor, butter, and powder. These include the cleaning/sorting machine, hydraulic press, breaker/vibrating screen, filter/blender, conching machine, tempering machine, and automated mechanized molder.

The cleaning/sorting machine sorts cocoa beans according to size. It operates on the basis of its cam-like sorting mechanism which affects the pull and push movement of the assembly. The hopper receives the cocoa beans then funnels them down the sorting stock where they are screened according to size. The sorted cocoa beans passed through corresponding slots down to the discharge chute.

The hydraulic press is used for processing of chocolate liquor with various components. Chocolate liquor is the liquid derived when processing cocoa beans. This liquid is squeezed out in the hydraulic press then processed further to make a fat-free powder.

The breaker, whose core is a set of blades similar to a fine saw encased in a stainless steel casing, is primarily used for the size reduction of cocoa nibs into powder.

The filter is basically a vibrating sieve to separate fine cocoa powder from coarse particles. Resting on the sieve holder is the top sieve with tubular rubber support. An electric motor located under

the sieve holder produces the required vibration. The base frame supports the entire machine.

The conching machine processes the cocoa into quality chocolate. The conching process produces minute cocoa and sugar particles smaller than the tongue can detect, hence the smooth feel in the mouth. The length of the conching process determines the final smoothness and quality of the chocolate. High-quality chocolate is conched for about 72 hours, and lesser grades are processed for about four to six hours.

Tempering is done to create the best possible conditions to initiate the development of stable crystals in melted chocolate. The correct structure of the crystals is necessary to obtain a perfect finished product. The tempering machine developed has a bowl at the top that contains the chocolate for processing. The heater regulates heat while the blower distributes it to attain the correct property of the product. Walling, frames, and the drive assembly provides the power requirement of the machine.

The molder is used to fill-up and process the chocolate liquor into the required shape. Its top portion, which is the adjuster clamp assembly, seals the tablea vessel. The vessel is filled with water and heated by an electric heater. The entire assembly rests on a fixed table which brings it to a comfortable height.

All equipment are with the ITDI and were already subjected to functional and trial tests. Field testing will be conducted from January to June 2015.



Cleaning / Sorting



Hydraulic Press



Vibrating Sieve



Breaker/ Pulverizer



Conching



Tempering



Three-Axis CNC LASER Machine

## DEVELOPMENT OF CNC LASER MACHINE FOR HIGH PRECISION MACHINING



The Project Team

The project “Development of CNC LASER Machine for High Precision Machining” supports the Makinarya at Teknolohiya Para sa Bayan (MakiBayan) program which provides a more enabling environment to spur growth in the metalworking and other related industries. The MakiBayan specifically aims to provide solutions to industry problems and develop needed machineries and technologies locally through strengthened R&D capabilities.

The MIRDC, in partnership with Inzpect Technologies, Inc., designed and developed a three-axis CNC LASER Machine system to address the technology needs of the local M&E industries. With LASER, the cut produced have a polished, finished edge requiring no post-cutting work. A 200-W power CO<sub>2</sub> LASER can cut and engrave in acrylics and metals (mild and stainless steel). With process speed of 20 m/min, machining time is reduced, thus, improving productivity. Currently, the project team is

doing endurance testing prior to commercialization.

A paper entitled “A Pulse-Width Modulation (PWM) LASER Power Controller for the 3-Axis Computer Numerically- Controlled (CNC) LASER Machine” was presented by the team during the 7<sup>th</sup> IEEE International Conference on Humanoid, Nanotechnology, Information Technology, Communication and Control, Environment, and Management (HNICEM) in Puerto Princesa City, Palawan. The said paper was also published in IEEE Xplore digital library.



Tablea Molder

## RETROFITTING OF A COMPACT RICE MILL FOR BROWN RICE PRODUCTION

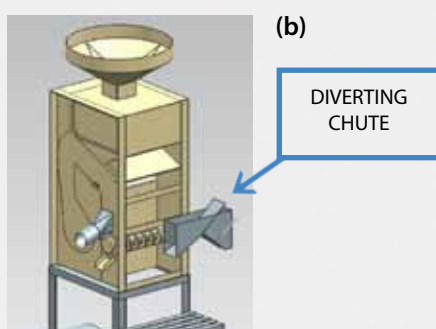
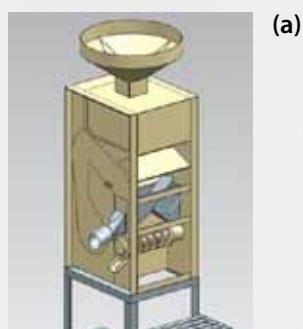

The diverting chute as attached to the compact rice mill.

In 2014, the Department of Science and Technology, thru the MIRDC, successfully retrofitted a compact rice mill system that can enhance brown rice production by allowing rice mill owners to produce brown rice without sacrificing the capability of the mill to produce well-milled rice. Moreover, this modification has the potential of reducing the amount of investment as compared

to buying a rice mill specific for brown rice.

The retrofitted compact rice mill system is currently located at the Philippine Center for Postharvest Development and Mechanization (PHilMech) in Nueva Ecija. One of its distinctive features is the diverting chute. This component diverts the dehulled paddy to either the right outlet which leads to a polisher to produce well-milled rice; or to the left outlet which leads the mixture of dehulled and unhulled paddy to a paddy separator for brown rice processing.

After thorough consideration of the minimum number of bucket elevators to be used, the ease of operation and other factors, the project team came

up with the design of the optimum layout for a motor driven compact rice mill system.

The retrofitted compact rice mill was tested with several brown rice varieties, namely: NSIC Rc 216, NSIC Rc 298, Dezu 300 and Black rice. Functional testing of the system showed an acceptable machine performance and an increase of 6-10% in milling recovery.

The economic feasibility of the project was likewise evaluated. Several scenarios such as types of ownership, percent of brown rice and milled rice production, and price of brown rice were studied. The result projected a substantial increase in income when a compact rice mill is retrofitted to produce both well-milled and brown rice. Moreover, the computed benefit cost ratio of 8.9 implies that the project is a wise investment and the commercialization of this project is very attractive.

Currently, the MIRDC is retrofitting another compact rice mill facility for a cooperative in Catabanan in Muñoz, Nueva Ecija. This will also include pilot testing which will provide data for the actual economic impact of the technology intervention.

The overall expectation is that by retrofitting compact rice mill facilities in the Philippines, rice supply could increase by 5-10% due to the increased milling recovery in producing brown rice.

## DEVELOPMENT OF FOOD PROCESSING EQUIPMENT

Under the High Impact Technology Solutions (HITS) Program of the DOST, the MIRDC, the ITDI, and the Project Management and Engineering Design Services Office (PMEDSO), in cooperation with the DOST Regional Offices, came up with DOST-developed food processing equipment for roll-out to the regions.

The MIRDC's major role in this project was to monitor the fab-

rication process of the following equipment: (1) water retort; (2) vacuum fryer; (3) vacuum packaging machine; (4) spray dryer; and (5) freeze dryer. These will be initially deployed to Food Innovation Center (FICs) in Regions 2, 5, 6, 8, 10, and 11. DOST Secretary Mario G. Montejo approved the request of DOST-NCR, and Regions 7 and 9 to also acquire the said equipment. Along with the deployment

of the said equipment, the DOST will also provide support services such as food testing, information, packaging and labeling design, consultancy services, trainings and seminars for its users. Simultaneous testing and deployment to all nine (9) regions will commence in 2015.



Spray Dryer



Vacuum Fryer



Vacuum Packaging Machine



Water Retort



Freeze Dryer

**In 2014, various food processing equipment were deployed in the FICs in these regions:**

Date	FIC/Region	Food Processing Equipment
12 May 2014	Region 11 – Philippine Women's College	Water retort, vacuum fryer, spray dryer
2 Sept 2014	Region 2 – Cagayan State University	Water retort, vacuum packaging machine, vacuum fryer, spray dryer
24 Nov 2014	Region 8 – Eastern Visayas State University	Water retort, vacuum fryer, spray dryer

The MIRDC also initiated the improvement of the existing food processing equipment which was mainly focused on increasing their production rate. This improvement initiative led to the creation of: the Continuous Type Vacuum Packaging Machine, which can simultaneously vacuum and seal three packs each with 1.5 kilos of meat; the Continuous Type Vacuum Fryer, that automatically feeds raw materials from a rotary feed valve to a vacuum cooking chamber before they leave the machine through a rotary discharge valve by means of a conveyor; and the Continuous Type Immersion Freezer, which also utilizes a conveyor so that feeding of material to the installed cooling chamber and discharging of the meat/marine produce to a collecting bin for final packaging into an insulated box occurs automatically. All processes in each of these equipment are integrated and automated, thus, operations no longer require full-time attention. Fabrication and testing of the machines are set to be completed by the end of June 2015.



Continuous-type Vacuum Packaging Machine



Continuous Type Vacuum Fryer

## IMPROVEMENT OF FLOOD CONTROL FACILITY THROUGH THE DEVELOPMENT OF AUTOMATIC TRASH RAKE

The DOST, through the MIRDC and the Local Government Unit of Quezon City (LGU-Quezon City), launched the Automatic Trash Rake (ATR) Facility that has the capability of removing garbage from heavily clogged waterways due to excessive garbage disposal in some canals in Quezon City. The project was also deemed to help in the rehabilitation of the San Juan River, one of Metro Manila's main river systems.

The facility makes use of an inclined conveyor type mechanism that uses motorized rake conveyors installed at the center of a congested creek to collect garbage. The design and development of the ATR Facility was a combined effort from the PMEDSO of the DOST and the different units of the Quezon City local government, particularly the Department of Engineering, Special Design Group, Environmental Protection and Waste Management Department, and Task Force Waterways.

The initial prototype was installed at Balingasa creek situated at the midpoint of G. Araneta Avenue cor. Mauban St. in Quezon City. Since the area receives ample amount of wastes from the Balintawak Market and nearby residential areas, the creek is sometimes clogged causing severe flooding in Barangays Masambong and Manresa in the vicinity. It was also identified

to cause flooding in some farther parts of Quezon City, particularly Talayan Village and the rest of Araneta Avenue.

Initially, a two-month endurance and performance testing was performed at the Balingasa Creek. The facility collected garbage from this upstream creek even before the waste goes into the San Juan River. Results showed that the ATR Facility can collect an average of 4 cu.m. of wastes per day during dry season and 6 cu.m. during the rainy season.



DOST Sec. Mario G. Montejo and LGU-QC Mayor Herbert Bautista at the launching of the ATR facility.



The Automatic Trash Rake facility at Balingasa Creek in Quezon City.

## ESTABLISHMENT OF A DIE AND MOLD SOLUTION CENTER

The establishment of the Die and Mold Solution Center (DMSC) is generally aimed at enhancing the competitiveness of the local tool and die sector in support of the components and parts manufacturing industry through the provision of facilities, technology, and manpower development. The DMSC is housed at the newly-renovated Mechanical Workshop I Building of the MIRDC.

Outputs of the DMSC project are focused on technology upgrade and modernization, and facilities and manpower development. Technology upgrade and modernization involved the acquisition of additional design and simulation software on plastic mold injection, blow molds and stamping dies. Further, simulation will be employed to achieve design optimization through translating CAD to CAE and CAM using software such as CIMATRON, Altair, Solidworks, and NX software.

Advanced machining (e.g., 5-axis multi-tasking, high speed), 3D printing, and CNC cutting (e.g. laser, router, plasma) are capabilities offered by the DMSC. In order to complement and upgrade the existing CNC machines at the MIRDC, top-of-the-line equipment such as additional 3-axis CNC machines and vertical machining centers, CNC EDM wirecut and sinkers, surface grinders, punch press, hydraulic shear, die spot press, power press, CNC CMM with laser scanning and vision system, and other auxiliary equipment are being put in place. Small and medium enterprises (SMEs) will be pro-

vided access to these advanced dedicated technologies and facilities through a shared-service-facility scheme at reasonable rates.

The manpower development component of the DMSC project involves the conduct of a six-month training program on Die and Mold Designing and Making (D2M2). The MIRDC's Technology Diffusion Division, the PDMA, Inc., the Technical Education and Skills Development Authority (TESDA), and the Technological University of the Philippines (TUP) collaborated to develop and finalize the curriculum and the selection criteria for trainees. A total of 20 participant-trainees were enlisted for the program. The course curriculum consists of 13 lecture topics and one (1) actual fabrication project where trainees will handle design of dies and molds.

The first batch of D2M2 will complete the training program in March 2015. Review and evaluation of the first batch will be conducted by the MIRDC and the PDMA Technical Working Group (TWG). Fine-tuning of the implementation of the training program will be applied in the next four batches, which will be funded by the DTI-Board of Investments under the Manufacturing Resurgence Program.

The DMSC project is under the Makinarya at Teknolohiya para sa Bayan (MakiBayan) initiative of the DOST, in cooperation with the Philippine Die and Mold Association, Inc. (PDMA, Inc.) and its launching was highlighted during the 2014 M&E



The new DMSC facility





D2M2 Trainees in action



DOST Usec. Amelia P. Guevara, DTI Sec. Gregory L. Domingo, DOST Sec. Mario G. Montejo and PDMA Pres. Philip C. Ang during the inauguration and launching of the DMSC.

Conference held on 18 June 2014 led by DOST Secretary Mario G. Montejo and Department of Trade and Industry (DTI) Secretary Gregorio L. Domingo.

Selected DMSC personnel attended several training programs within and outside the country to boost their capabilities in properly sustaining the operations and maintenance of the newly-upgraded facility. This will also aid in providing the industry with the most relevant consultancy and training services on specialized techniques and procedures related to tool, die, and mold designing and making.



DMSC Machines and Equipment

## FLUIDIZED BED DRYER PROJECT

The DOST, through collaborative efforts of its agencies, initiated several projects that will significantly contribute to rice self-sufficiency. These projects particularly focus on the improvement of the shelf life of brown rice. Earlier studies have identified brown rice as a cost-effective way of achieving rice sufficiency mainly because of its higher milling recovery. However, its short shelf life is a major drawback that hinders brown rice marketability and consumption by the public.

Experiments conducted by the Food and Nutrition Research Institute (FNRI) revealed that a combination of steaming and drying is an effective method of increasing the shelf life of brown rice without significantly affecting its nutrient contents, as well as its physico-chemical, chemical and microbiological properties. It is for this reason that the MIRDC implemented projects involving the design and development of equipment for the stabilization of brown rice and consequently prolonging its shelf life. One of these projects is entitled, "Development of a Fluidized Bed Dryer (FBD) for Production of Stabilized Brown Rice (SBR)," aimed to design and fabricate a low-cost prototype batch type and likewise a continuous type FBD. The batch type prototype will have a 50 kg/batch capacity while the continuous type prototype will be 1 ton/hour.

In the first quarter of 2014, the project team attended a short training course on designing fluidized bed dryer in Vietnam Institute of Agricultural Engineering and Postharvest Technology (VIAEP) – Hanoi, Vietnam. The existing fluidized bed dryer system of VIAEP was documented and the actual running test was carefully observed. Results of this activity, coupled with the data obtained from earlier benchmarking of fluidized bed dryer systems in the country, enabled the project team to come up with the final design of the prototype batch type FBD and initial design of the prototype continuous type FBD.

Mariñas Technologies, Inc. started the fabrication of the prototype batch type FBD on the third quarter of 2014. As of December 2014, fabrication was 90% completed. Most of the framework and major components of the system have been fabricated while the control system is still being worked on. The fabrication of the prototype is expected to be completed: on January 2015; debugging and testing shall commence immediately.

The team is confident that the outcome of this project will benefit the rice millers, cooperatives, and Small and Medium Enterprises (SMEs) engaged in brown rice production.



Rice hull as fuel source of the Fluidized Bed Dryer.



MIRDC team visits FBD facility at VIAEP in Hanoi, Vietnam.

## DEVELOPMENT OF A LOW-COST AND LOCALLY DESIGNED METEOROLOGICAL BUOY

To support and enhance the efforts of the Philippine Atmospheric, Geophysical and Astronomical Services Administration (PAGASA) in modernizing its ocean observation and weather forecasting system, the MIRDC, in partnership with the Advanced Science and Technology Institute (ASTI) and the PMEDSO of the DOST, designed and developed low-cost and sustainable Meteorological Buoys (MetBuoys) system.

MetBuoys are used to monitor sea changes especially during extreme weather conditions. These buoys, equipped with necessary sensors, are capable of real-time data acquisition of different parameters such as wind, relative humidity, air temperature, barometric pressure, rainfall, and sea temperature. Moreover, through accurate and timely data collection and monitoring, these buoys will be used to alert or prevent impending dangers brought about by catastrophic weather conditions.

The MIRDC project team successfully fabricated two MetBuoy prototypes that were deployed and pilot-tested in the island of Corregidor. Data from the instruments were effectively relayed to a central server maintained by ASTI where all data acquired by the MetBuoy sensors are consolidated and processed. A management system software was developed for data interpretation and visualization. Ultimately, the processed data were transmitted to PAGASA and other accredited users such as disaster response organizations and local government units.

On its second year of implementation, the project team developed another two MetBuoy prototypes. These were designed and fabricated considering the adjustments deemed necessary to improve the previously developed prototypes. One MetBuoy system was deployed in Matnog, Sorsogon during the latter part of May 2014

and the other unit was deployed in Aborlan, Palawan in June 2014. The same set-up for data collection, processing and transmission will be employed.

The respective local government units are tasked to secure and monitor the MetBuoys. Although the overall maintenance and operation rests with PAGASA, Information and Educational Campaigns were purposely conducted last December in both deployment sites to involve the local communities in the project and assist on its monitoring and protection.

The successful development and deployment of MetBuoy prototypes has prompted the project team to work on the development of a commercial MetBuoy model. This phase is seen to broaden the scope of the project and aid in the further realization of its objectives.



MetBuoy assembly and deployment in Matnog, Sorsogon.

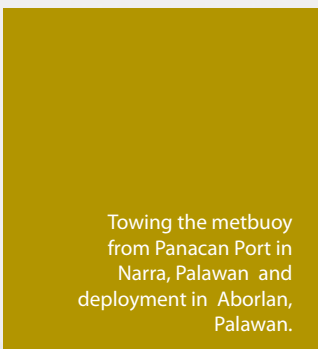

Towing the metbuoy from Panacan Port in Narra, Palawan and deployment in Aborlan, Palawan.



## DESIGN AND DEVELOPMENT OF HAND TRACTOR ATTACHMENTS (HARVESTER AND TRANSPLANTER)



Functional testing of the hand tractor-attached harvester.



Field testing of the hand tractor-attached transplanter.

The development of hand tractor-attached transplanter and hand tractor-attached harvester is the main activity of the project entitled, "Design and Development of Hand Tractor Attachments (Harvester and Transplanter)" under the program "Enhancing Rice Production and Postproduction Efficiencies Through Improvement and Use of Appropriate Mechanization and Postharvest Technologies." This is in partnership with the Philippine Center for Postharvest Development and Mechanization (PHilMech), funded by the Philippine Council for Agriculture, Aquatic, and Natural Resources Research and Development (PCAARRD).

This project is working on a new concept in rice mechanization through the development of the hand tractor-attached transplanter and hand tractor-attached harvester. These prototypes have rice transplanting and harvesting implements that can be readily mounted to and dismounted from the common hand tractor. The availability of such implements is aimed to significantly increase the utilization of hand tractor in farm areas as well as reduce the cost of farm level mechanization that will directly benefit the farmers, rice field owners and planters.

The development of hand tractor-attached transplanter prototype was fully completed in mid 2014.

This prototype has undergone a series of functional testing at the MIRDC and three (3) field testing in selected areas. The first field testing was performed in the compounds of PHilMech and Philippine Sino Center for Agricultural Technology on January 28 to 30, 2014; the second field testing was held at the rice field of Amucao Seed Growers Agro-Industrial Cooperative (ASGA-IC) in Amucao, Tarlac on April 1 to 4, 2014; and lastly, at the demo farm of PhilRice on June 23 to 27, 2014. Modifications and revisions of the hand tractor-attached transplanter prototype were carried out based on the results of the testing for its improvements. The hand tractor-attached transplanter is driven by a 7HP diesel engine and has a capacity of 0.5 hectare per day through its four-row planting capability. Its planting distance is within 20 cm to 25 cm as required by the Philippine Agricultural Engineering Standards (PAES). Furthermore, it has a feature that can adjust planting depth making it comparable to commercially available transplanters.

The design and assembly of hand tractor-attached harvester prototype were likewise completed. Initial functional testing was done on December 2014 in the welding shop of the Prototyping Division.

### Target specifications of the hand tractor-attached harvester prototype

IDENTIFIED SPECIFICATIONS	TARGETS SPECIFICATIONS OF HARVESTER PROTOTYPE	REMARKS
working width	0.8 meter	comparable to self-propelled commercially available handtractor combined with harvester
working efficiency	500 m <sup>2</sup> per hour	
loss ratio	≤ 3.5%	
impurity ratio	6%	
power requirement	minimum of 7 HP; varies depending on the engine of a hand tractor	

## DESIGN AND DEVELOPMENT OF A LOCAL MICROWAVE VACUUM DRYER

In the second year of project implementation, the project team was able to finalize the designs of the rotary drive assembly and the refrigeration system. These were subsequently fabricated with consideration of all microwave technology requirements. Moreover, the control box was successfully tested to control the rotary speed of the motor drive assembly. Full testing will be done upon complete integration of all the components.

Meanwhile, the MIRDC project team, together with the UP project team, conducted the mixing behavior test of rice bran in a rotating canister where different rotating speeds were used. They also performed vacuum drying experiments with different drying time. Data gathered from these experiments will be compared with those from the microwave vacuum dryer.

Another accomplishment of the project is winning the 'Best Poster Paper' award during the 7th

IEEE International Conference on Humanoid, Nanotechnology, Communication and Control, Environment and Management (HNICEM) held at Puerto Princesa City in Palawan. This will be presented again at the International Multiconference of Engineers and Computer Scientists 2015 (IMECS 2015) in Hong Kong.



Integration of Major Components of an MVD.



Above: Poster Presentation of the Project in 7th IEEE HNICEM.

Left: Mixing Behavior Test and Vacuum Drying Experiments of Rice Bran in a Rotating Canister.



The MIRDC and UP Project Teams.

## DEVELOPMENT OF 12-HORSEPOWER SINGLE CYLINDER DIESEL ENGINE

The DOST, through the MIRDC, undertook research activities to localize a 12-hp single cylinder engine in cooperation with different stakeholders from the private sector, agricultural agencies, and the academe in order to meet high domestic demands. Since no local company is producing such engines, the country resorts to importation.

Project-related activities include the completion of the model unit's engine disassembly and chemical analysis of engine components using X-ray Fluorescence. Engineering drawings and dimen-

sional analysis of engine components are being finalized.

The 12-hp single cylinder engine to be locally developed by the project is aimed to be 20% lower in cost than the leading brand. The project also aims to establish a pool of local manufacturers and suppliers of parts and components to sustain the local production of the engine upon commercialization.

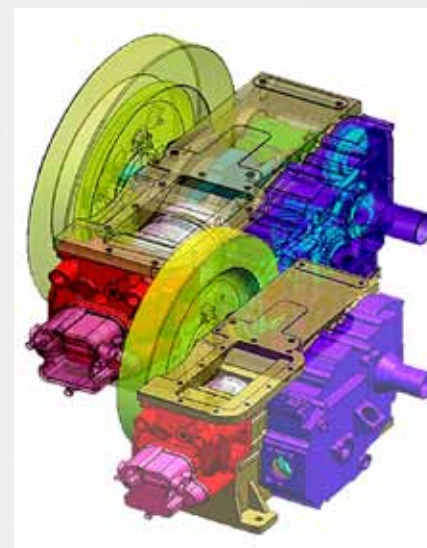

3D drawing of Single Cylinder Diesel Engine.

## DESIGN AND DEVELOPMENT OF SUPERHEATED STEAM TREATMENT SYSTEM FOR STABILIZED BROWN RICE (BATCH TYPE AND CONTINUOUS TYPE)

The “Design and Development of Superheated Steam Treatment System (SSTS) for Stabilized Brown Rice (Batch Type and Continuous Type)” is another project that envisions to support the national government in achieving rice sufficiency. This was implemented to address the Research & Development Program of the DOST to identify factors affecting the stability and acceptability of brown rice after processing and storage.

In the absence of brown rice treatment technology, the MIRDC together with the FNRI and the PMEDSO, designed and developed a batch and a continuous type superheated steam treatment system that will extend the shelf life of brown rice from the present one - two months to five – nine months. The MIRDC is tasked to design, fabricate, assemble and test the functionality of the superheated steam treatment system; the FNRI is assigned to develop of standardized processing parameters of superheated steam treatment system for the production of SBR; and PMEDSO is required to provide support on other technical aspects.

During the first year of implementation, the project team completed the prototype batch type superheated steam treatment system with an overall dimension of 2.75 m x 1.4 m x 1.7 m, and a capacity of 10 kgs. per batch, and treatment time of up to 3 minutes. The system has a conveyor driven by a 1hp electric motor and a control system for easy loading, spreading and discharging the brown rice after treatment.

Superheated steam is supplied by a 5-BHP boiler and a super heater that transforms saturated steam into superheated steam with a temperature of up to 300°C. Both the boiler and super heater are fabricated based on ASME and PSME standard to

assure efficiency and safety during operation; while all parts of the system that come in contact with the brown rice are made of food grade stainless steel.

With a combined process of steaming and drying, the system utilizes superheated steam with a temperature of up to 175°C. This condition softens the fibrous layer and dries brown rice to make it permeable thus lessening the cooking time. This process will likewise deactivate the spoilage-causing enzymes present on the bran; preservation of the nutrients, sensory acceptability, and quality of brown rice can be done without the aid of chemical additives.

The design for a continuous type SSTS with a capacity of two (2) tons of brown rice per hour was already conceptualized, reviewed and finalized. Likewise, all the documents for bidding process are already prepared.

Compared to batch type prototype where brown rice is kept for a certain time during treatment, the continuous type prototype keeps the brown rice in constant motion throughout the operation. The grains will be initially poured into the feeding hopper, conveyed to the treatment cylinder, and then subjected to superheated steam treatment. The treatment cylinder has a spiral mechanism that controls the movement and mixing of brown rice while being conveyed from the entrance to the discharge chute. Treated brown rice from the discharge chute will then proceed to the cooling unit for stabilization.



Prototype of Batch Type Superheated Steam Treatment System.



Brown rice in discharging chute.

**O**ver the years, the Materials and Process Research Division has strengthened its research and development capabilities by engaging in projects that are not only challenging, but meaningful to the industry as well. As an R&D unit of the MIRDC, the MPRD gave a huge contribution to a successful 2014.

In 2014, the MPRD steadfastly implemented projects in order to bring the metals and engineering industries to an increased level of vitality. Dedicated personnel of the MPRD make up teams involved in several important projects such as those related to advanced transport, disaster mitigation, and surface engineering. With the remarkable dedication of MPRD employees, the Division will be able to complete all its undertakings and effectively deliver all R&D outputs to increase the productivity of the M&E industries.

## Demonstration of the Operational AGT System at UP Diliman

The Automated Guideway Transit System (AGT) in the University of the Philippines (UP) Diliman, Quezon City has been under research and development for more than three years by the Department of Science and Technology (DOST) through its implementing agency, Metals Industry Research and Development Center (MIRDC). As part of the continuous design and improvement of the system, two passenger stations equipped with automated fare collection system, and communication and safety features were established.

High-ranking officials including the members of the Science and Technology (S & T) Committee of the House of Representatives and other stakeholders expressed their interest to support the technology during the public demonstration for the Tour and Presentation of the DOST Flagship Projects held on March 12, 2014 at UP Diliman. The AGT took the passengers from Station 1, E. Jacinto St. near the UP College of Fine Arts, to Station 2, C. P. Garcia Avenue, and back. Among the prominent figures who joined DOST Secretary Mario G. Montejo during the said event were Sen. Cynthia A. Villar, Hon. Victor J. Yu, 1st District of Zamboanga del Sur, Hon. Peter M. Unabia, 1st District of Misamis Oriental, Hon. Jose F. Zubiri III, 3rd District of Bukidnon, Hon. Marie Ann S. Pernes, lone District of Siquijor, and Hon. Thelma Z. Alamario, 2nd District of Davao Oriental.

Several media groups documented the said event. Senator Villar expressed upon alighting the AGT coach, "This one is elevated, so parang may second floor 'yung ating mga streets, 'di ba. Mayroon pa rin sa ilalim, mayroon pa rin sa taas, so madi-decongest ang traffic."

As a sequel to the free public ride on the AGT during the UPD Lantern Parade last December 18, 2013, the project team once again treated the public to a month long free ride on the AGT from June 9-26,

2014. The Project staff assisted the passengers composed of UP students and instructors, and residents within the UP premises.

Last June 10, 2014, Officials and Engineers from North Luzon Railways Corporation (NLRC) led by their President, Conrado K. Tolentino, visited the AGT's Public Demonstration. Aimed to introduce the system to the NLRC and to discuss the possible partnership between the two organizations, the project team prepared a brief presentation of the AGT System. Secretary Montejo proposed that the DOST, through the MIRDC, could develop the rolling stock and coach assemblies



Senator Cynthia A. Villar and some congressmen use smart cards as payment medium to pass on the automatic turnstile gates.

while the NLRC could do the civil works, tracks and stations. After the said meeting, President Tolentino together with Vice President Jesus Enrico Moises B. Salazar and other NLRC Engineers were invited to a ride on the AGT.

The said demonstration likewise served as simulation of the use of the AGT passenger stations and automatic ticketing system providing smart cards for each of the passenger. Moreover, passenger survey forms were given to gather responses regarding the facility, stations, and the collection system, to be used in the continuing research and development of the project.

The public demonstrations of the operational AGT System and fully functional passenger stations were carried out in order to determine the likelihood of public acceptance and assess how well it can meet the urban transportation needs.



DOST Secretary Mario G. Montejo accompanies Senator Cynthia A. Villar (3rd from left) and other members of the S & T Committee of the House of Representatives.

From Left - Hon. Marie Ann S. Pernes, Hon. Thelma Z. Alamaro, Sen. Cynthia Villar, Secretary Montejo, Hon. Victor J. Yu, and Hon. Jose F. Zubiri III.



## Test and Evaluation of 120-Passenger Per Coach Capacity Automated Guide-Way Transit System

The project entitled, "Test and Evaluation of 120-Passenger per Coach Capacity Automated Guide-way Transit System" was launched soon after the development of the AGT-Bicutan specifically aimed to test and evaluate the technology in terms of its safety, energy, and technical viability.

The project team coordinated closely with representatives from the Philippine Textile Research Institute (PTRI), National Research Council of the Philippines (NRCP), and the Local Government Unit (LGU) of Taguig to ensure smooth implementation of the project. Several achievements had been noted. In the first two quarters of the year, the prototyping activities such as the completion and integration of mechanical, electrical, and control component, the energization of the track, and the lifting and mounting of the rolling

stocks including the integration of the components were all accomplished. These activities were followed with several functional test runs which lasted for three months. These were done to verify the functionality of the components and parts. The findings and corrective actions from the test runs were logged, monitored and addressed accordingly. Additional safety features such as retainer assembly, park brakes, motor catch bracings, safety gratings, and tire barriers were installed to reinforce the safety design features. The test protocols were already finalized and approved. A series of performance test runs which can help in the collection and analyses of data is currently being conducted.

The development of the AGT Bicutan complements the ongoing development in C-6. If feasible, there will be an extension of the

track from Bicutan to C-6, and possibly all the way to Rizal. This is to further realize the full potential of the technology with longer tracks and equipped with passenger stations and communication and fare collection systems. Through this cost-effective, energy-efficient, and environment-friendly transport alternative, it is envisioned that this will help strengthen connectivity and access to various areas. It can also help reduce the traffic bottlenecks, promote greener environment, and propel economic growth in the long term.



AGT120 staff installing the retainer assembly to bolster the safety design features of the AGT system.

## Development of Prototype Trainset

At present, the Philippines faces a crisis in the transportation sector made evident by congested traffic resulting to wasted time and energy that directly impacts the development of the economy, protection of the environment and the welfare of the population. The railway system is considered a solution to the transportation crisis in the Philippines with its roster of advantages listed by European and other developed countries. These advantages include safety, speed, capacity, comfort, environmental protection, traffic jam reduction and economic feasibility.

With the aim to contribute to the modernization of transportation system in the Philippines, the MIRDC, one of DOST's research and development institutes, embarks on a project that will develop a five-coach prototype steel wheel Trainset. This project is under the agency's Support Program for the Productivity and Competitiveness of the Metals & Engineering Industries.

There are three major railway systems currently operating in the country—the Metro Railway Transit (MRT), Light Rail Transit (LRT Lines 1 & 2) and the Philippine National Railways (PNR). However, since these are outsourced technology, the Philippine government spends a big chunk of its budget for patent and maintenance fees. In many instances, the country can barely afford these expenses due to other major priority concerns. In effect, both the government and the train-riding public end up

spending on transportation that is not used to its full potential.

In view of the above, the MIRDC is working on the design and fabrication of a five-coach prototype Trainset. The Trainset is envisioned to improve the current operations of the PNR by raising efficiency while lessening production and operational costs. This project also aims to utilize and maximize the capabilities of local industries in the fields of metals and engineering enabling the country to generate its own technology to address needs in the area of transportation. The scope of work includes the development of a control system for the Trainset and the completion of a comprehensive material selection process for the local production of train parts and other requirements.

The project activities for 2014 focused on completion of components particularly that of the bogies: procurement of bogies which will reduce all the bogie components such as dampers, axlebox, suspensions, and wheelsets into one assembly; pro-



A common scene on the Philippine railway systems where there is no enough trainsets to accommodate the commuting masses.



(Left) Inspection of passenger coaches of the Prototype Trainset. (Right) Fabrication of the power coach.

curement of the structural and mechanical items for the project; and conduct of tests to ensure integrity of the welded parts.

Also in 2014, activities focused on component completion for coaches that includes: finalization of the fabrication of coach and chassis; Terms-of-Reference (TOR) and technical specifications of coach; application of some minor modifications from the original design of the coach prior to fabrication; and the implementation of face lift design to improve the aesthetics of the pilot and power coaches.

The Project Team attended the railway conference in Malaysia on May 7-9, 2014. The conference showcased the various suppliers from around the world who displayed and discussed their products useful for the Railway Industry. It also served as the venue for the various railway authorities within Southeast Asia to give updates on the needs and improvements in their respective countries. The team learned from the Malaysian experience in railway operations which is a pioneering example within Southeast Asia. The team met suppliers for the wheelsets and visited a Malaysian facility, SMH Rail, a Malaysian railway engineering service provider

that specializes in re-engineering and refurbishing an old railway located in the Klang, south of Kuala Lumpur.

In 2014, the following components were delivered:

- Six (6) units of Chassis from Fil-Asia Industries;
- Twenty-six (26) pieces of Lead-Acid Batteries from Lead Core Technology; and
- Twelve (12) units of 125 hp & 30 hp motors and Twelve (12) units of 125hp and 40 hp VFDs from BJ Marthel International, Inc.

A month after the awarding of the bogie assembly, Shung Shin Rolling Stock Technology, Inc., manufacturer of bogie assemblies of railway trains as well as finished automobiles, invited the project team together with Engr. Rodnel O. Tamayo, the Division Chief of the Materials and Process Research Division (MPRD), Engr. Jonathan Q. Puerto, the Program Leader and Deputy Executive Director for Research and Development, Asec. Robert O. Dizon, the Officer-In-Charge of the MIRDC and Assistant Secretary of the DOST and Sec. Mario Montejo, the Secretary of the DOST, for a plant visit at Changwon, South Korea. The object of the plant visit is to build strong partnership and link-

ages with the research and development institution that has been providing top-grade rolling stock technologies. This opportunity will help the country broaden the local industry's technical expertise through practices and experiences in railway technology. The team also aimed to evaluate the current existing manufacturing processes and facilities, and study if the technology is adoptable or tailor-fit to the Philippine setting.

The plant tour was complemented by technical discussions between the Sung Shin Corporation officers and the DOST delegates. Mr. Park discussed Sung Shin Corporation's values and visions, organization, the main products and services, worldwide customers and business plan and projects. The DOST delegates inquired about capabilities of the manufacturing plant, such as the compressive force of the Compression Testing machine, Korean standard for the service life of a train, and their capability to manufacture a customized design train. The group learned that: 200 tons of compressive force is applied in testing a train structure; the standard service life is 25 years; and the company can build a customized design train.



DOST delegation pose with Shung Shin officials.



One of the testing machines at Shung Shin.

Possibilities for local gangway production has been initiated through a meeting with SSI Rubber. The supplier stated that they can provide gangways with inner and outer bellows upon the specifications of the trainset. They can also adapt the commercial gangways that can adjust to the climatic changes of our country.

The project team maintains close affiliation with the Philippine National Railways (PNR) through Engr. Ruben Besmonte, the Rolling Stock Maintenance

Department Manager. The PNR offered to extend help for the testing and inspection of the procured bogie assemblies.

The project team is looking forward to the integration of mechanical and electrical components upon the delivery of the coaches and bogie assemblies in February 2015.

## Development of Tent System for Emergency Applications

The project will develop tent systems that can be used to provide immediate shelter to people displaced by a calamity or disaster. A multipurpose tent will also be developed to serve various functions such as temporary warehouse, field hospitals and command centers.

At present, available temporary shelters are mostly from foreign stockpiles such as from the United Nations High Commissioner for Refugees (UNHCR) and other donor countries. Due to the vulnerability of the Philippines to climate change, many people are expected to be affected and displaced,

and most of these aids are not enough to cover the emergency requirements. In the case of the Philippines being archipelagic, logistics also poses a challenge to the delivery of supplies. In this regard, the tent systems will also be designed to enable fast manufacturing not just by committed tent manufacturers but also by other manufacturing sectors such as the metalworking and the garments sector. The tents must also be cost-effective and durable enough to serve as temporary shelter until such time people can rebuild and return to their homes.



## Cast Wear Service Parts Improvement

Through the years, the MIRDC's MPRD has been committed to providing the Philippine M&E industries with technical expertise on research and development through contract research. Many of the industry sectors, both government and private, have benefited from this undertaking.

In 2014, one of the major researches MPRD engaged in is on the improvement of Cast Wear Service parts with the Electa Tarlac Aggregated Corporation (Electa), a company engaged for the past 20 years in the production of aggregates and sand used in the construction industry.

To realize the primary objective of the study, which is to intensify the value of cast parts by improv-

ing the service life, lowering the throwaway weight and preventing premature failures, the research is divided into two (2) major phases:

- **Phase 1: Purchasing Requirements and Specifications Standardization**

Refers to the standardization of the specifications, technical requirements and acceptance criteria on acquisition of cast wear parts ordered from local foundries and other suppliers. This may involve identification and characterization of castings with the historically highest service life which may be used as a benchmark in setting the service life target.

- **Phase 2: Parts Profile and Grade Optimization.**

Apart from the mechanical design, chemical composition, microstructure and processing technique of the cast wear parts, the conditions of application contribute significantly to the performance. To fully maximize the utilization of parts and prolong the serviceability, the composition grade and profile must match the operational condition.

Other factors affecting the wear and tear rate of cast parts are shown on the chart on page 35.

The research team headed by Engr. Lemuel N. Apusaga has already conducted several meetings with Electa and its major parts sup-



pliers, Tiger Machinery and Arty Foundry. This is to secure support and cooperation in the standardization of specifications which is envisioned to result to a uniform service life of cast wear parts regardless of the foundry/supplier.

Samples of the existing parts being used by Electa were subjected to metallographic and chemical analysis from which data gathered will be used as basis for improvement of composition.

Review of literature related to profile optimization of parts profile, particularly the plates of jaw crushers, to the characteristics of rocks and the crushing condition/operation has been completed. The team has established preliminary jaw plate profile to be implemented for both the San Jose and Mayontoc plants.

Based on the initial observations, a possibility that the crushing equipment is underrated for the type of rocks to be processed, which may be affecting the service life of the equipment, was noted. Rock samples were sent to METSO in Finland for further analysis.

In addition, training and certification of Electa personnel who will conduct the magnetic testing and failure analysis are also part of the support to the on-going profile optimization.

The overall impact of the project would be longer service life, higher reliability of the components and more effective scheduling of shutdowns for maintenance works. To an extent, the project will increase the productivity of the plant by maximizing the service life of the spare parts.

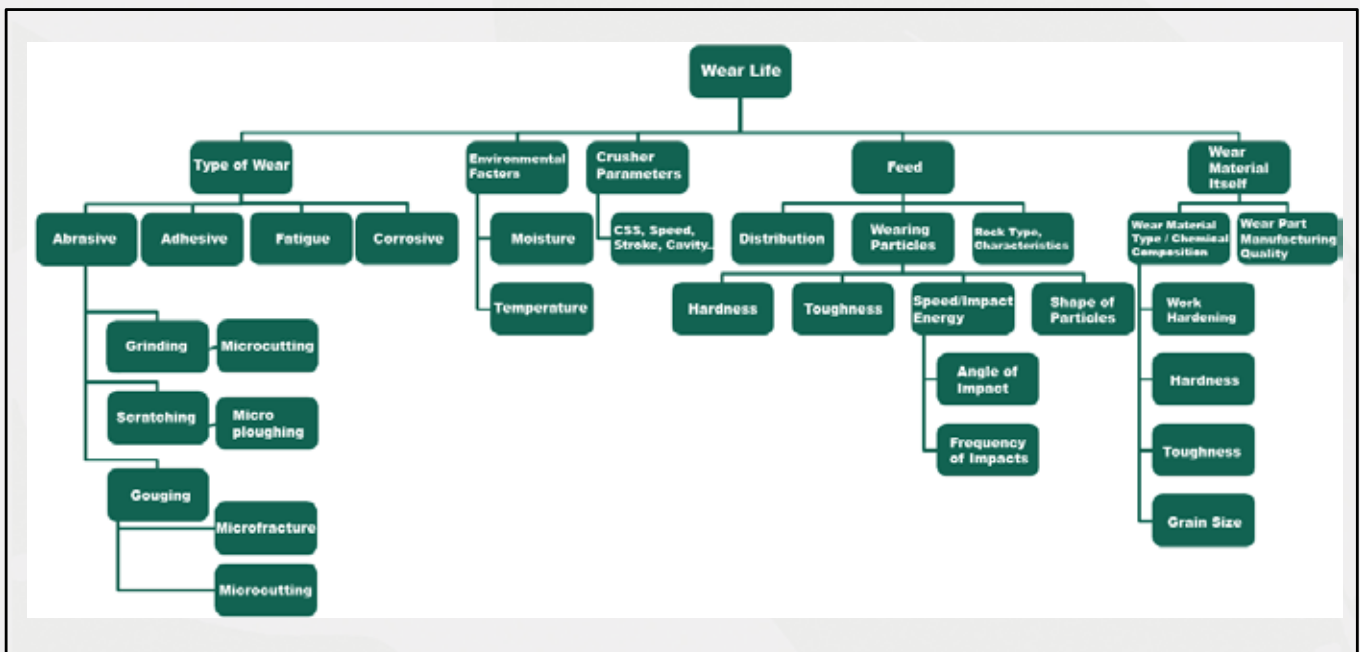

Factors affecting the wear and tear rate of cast parts.



Jaw plate in action



Crushed rocks from the jaw crusher



Spare jaw plate

## Surface Engineering

The MIRDC established new facilities in response to the increasing technology demands required by the Surface Engineering sector to make the local industry competitive. These two facilities are:

- (1) Hard Anodizing Facility; and
- (2) Vacuum Heat Treatment Gas Quench Facilities

### Hard Anodizing

The anodizing process is an environment-friendly electrochemical process that involves conversion of aluminum metal surface into a porous aluminum oxide, ultimately creating an end product whose finish is more durable and weather-resistant. This beneficial result combined with the array of aesthetically pleasing color finishes opens up endless application possibilities for companies who anodize products and components in commercial, in-

dustrial, and consumer applications, even jewelry and artwork.

Most anodized products have an extremely long life span and offer significant economic advantages through maintenance and operating savings. Moreover, an increasingly large number of gloss and color alternatives are available for aesthetic value.

The MIRDC has established an anodizing facility with the following line-up: 30"x30"x25" PVC tanks each with 400-liter capacity, direct current (DC) and pulse rectifiers as power sources, and waste treatment facilities such as chiller, cooling tower, and fume scrubber. The set up also has its own de-ionizing water system.

Through the establishment of this new facility, the requirements for surface finishing technology is continuously supported.



A complete line of anodizing process: cleaning, etching, desmutting, anodizing, dyeing, sealing and drying.



A rectifier is an electrical device used as a direct current power source to operate any plating or anodizing system.



The scrubber helps control air pollution by removing some particles and/or gases from industrial exhaust streams and the cooling tower transfers process waste heat to the atmosphere.

## Vacuum Heat Treatment Gas Quench Facilities

Vacuum heat treatment is a process where heating and cooling of metals are controlled to alter characteristics of their microstructures in order to achieve desired changes in the physical and mechanical properties. This process is performed in a space relatively devoid of matter.

Heat treatment of metals is done for one of the following general reasons: softening, hardening and material modification. Vacuum is used as “protective atmosphere” to prevent contamination

of metal surfaces. Additionally, heat treated metals are free from surface oxidation and decarburization giving a bright, metallic and shiny surface with clean, dry parts after hardening. Also, homogeneous quenching uses an inert gas and the distortion is reduced.

The Vacuum Heat Treatment Furnace (VHTF) at the Surface Engineering Building of the MIRDC is utilized for direct hardening and softening (e.g., tempering), with softening using conventional heat treatment furnace as alternative.

### Technical Specifications and Operating Parameters

Furnace Type	Batch type horizontal internally heated, horizontal loading and unloading
Loading Capacity	200 kg/batch (including the weight of charging tray and jig)
Soaking zone size	600mm (L) x 400mm (W) x 400mm (H)
Highest temperature	1300 °C
Working temperature	550 °C ~ 1250 °C
Cooling water	Pressure: 0.1~0.2 MPaG Temperature: 15 °C - 30 °C
Compressed air	Pressure: 0.5~0.6 MPaG
Nitrogen Gas Requirements	<b>Protective Gas</b> Pressure: 0.2 MPaG Purity: 99.999% Flowrate: 0.6~3 Nm <sup>3</sup> /hr <b>Cooling Gas</b> Pressure: 0.2 MPaG Purity: 99.999% Flowrate: 4 Nm <sup>3</sup> /hr
Electrical Capacity and Load	AC 440 V three phase 60 Hz, 135 kVA total load
Accepted materials for heat treatment	Tool Steels, Stainless Steels, High Alloy Steels





Engr. Nelson L. Tumibay explains the vacuum heat treatment furnace operations.



A technical staff charges D2 Tool Steels into the VHT Furnace for hardening heat treatment.



A HT personnel performs hardness testing on heat treated samples.

**The Industrial Training Section (ITS) was awarded in June 2014 as the Best Organizational Unit because of their commendable performance during the previous year.**

**Year 2014 is another productive year for the ITS, with one hundred thirty one (131) training programs implemented and two thousand eight hundred sixteen (2,816) generated participants coming from both private and government sectors. These executions have been successful because of the strong support of every division and section chiefs of the Center. They liberally involved their workforces in serving one of the Center's missions which is to provide both government and private sectors in the metals and engineering industry with professional management and technical expertise on the training of engineers and technicians.**

Hence, the Center will continuously support the M&E industry requirements in accomplishing their plans and programs through developing and enhancing the knowledge and skills of employees in their particular field of specialization.

The summary of training programs conducted with the corresponding frequency of implementation and number of persons trained are as follows:

### Summary of Regular Training Programs Conducted in 2014

Title of Training Programs	Frequency of Programs Conducted	No. of Trained Persons
Basic Plastic Injection Mold Design	1	3
Developing & Implementing a Laboratory MS Based on ISO/IEC 17025	1	17
DM 2: Basic Length Calibration	4	52
DM 3: ISO Limits & Fits & Inspection of Geometrical Tolerances	1	12
DM I: Basic Measurement	5	101
Documenting a QMS Conforming to ISO 9001:2008 Standard	1	7
Electroplating Processes	2	10
Establishment of Preventive Maintenance System	2	19
Fundamentals of Corrosion	1	8
Heat Treatment of Steels	1	7
Industrial Calibration	3	82
Internal Quality Audit	1	9
Machine Shop Operations	1	7
Metal Fabrication	1	3
Metals Identification & Selection	2	17
Nondestructive Testing	1	9
Plastic Injection Molding Machine Programming & Operations	1	5
Production Planning and Control	1	5
Productivity Improvement Through 5S Practice	1	14
Product Costing	1	13
Project Management	1	4
Shielded Metal Arc Welding (SMAW)	1	5
TIG Welding on Carbon Steel Pipes	1	4
TIG Welding on Carbon Steel Plates	2	7
Uncertainty of Measurement	1	11
Verification of Common Laboratory Instruments	1	10
<b>Total :</b>	<b>39</b>	<b>441</b>

### Summary of Packaged Training Programs Conducted in 2014

Title of Training Programs	Frequency of Programs Conducted	No. of Trained Persons
Brazing Procedure & Performance Qualifications	1	30
Condition Monitoring System & Vibration Signature	1	38
Feasibility Study Preparation	1	10
GMAW & GTAW Processes	1	4
Heat Treatment of Steels	1	5
Internal Quality Audit	1	16
ISO/IEC 17025 Awareness	2	45
Machine Shop Operations & General Welding Processes	2	29
Machine Shop Operations (Conv. Milling & Grinding Operations)	3	29
Plastic Injection Molding Machine Programming & Operation	1	10
Productivity Improvement Through 5S Practice	1	32
The Basics of Die Design and Fabrication and The Fundamentals of Pressworking	1	8
TIG Welding	2	12
<b>Total:</b>	<b>18</b>	<b>268</b>

### Summary of Regional Training Programs Conducted in 2014

Title of Training Programs	Frequency of Programs Conducted	No. of Trained Persons
AS 9100:2009 QMS	1	13
CNC Machine Tool Programming & Operations	29	573
Electroplating Processes	1	6
Gemstone Processing	1	12
GTAW & GMAW Processes (B1 & B2)	2	16
Info. Sem on Establishment of Preventive Maint. System	3	78
Info. Sem. on CNC Milling Programming & Operations	1	18
Info. Sem. on ISO 9001:2008 Awareness	3	179
Info. Sem. on Metals Identification	1	131
Info. Sem. on NDT	1	146
Info. Sem. on SMAW	1	34
Info. Sem. on TIG Welding	1	19
Info. Sem. on Welding Symbols	1	135
Info. Sem. on Welding Arc Safety	1	140
Info. Sem. on Welding Joint Design	1	143
Info. Seminar on Effective Presentation Skills	1	22
Info. Seminar on Productivity Improvement Through 5S	1	31
Internal Auditor Training Course	1	11
Internal Quality Audit	1	17
Internal Quality Audit (ISO/IEC 17025)	1	14
ISO 9001:2008 Awareness	3	102

## Summary of Regional Training Programs Conducted in 2014 (continuation)

Title of Training Programs	Frequency of Programs Conducted	No. of Trained Persons
Machine Shop Operations	1	19
Machine Shop Operations w/ Basic Gear Making	1	10
Metal Fabrication with Wrought Iron Forming	3	31
Metals ID & Selection	1	18
Office 5S	1	17
Oxyacetylene Welding & Cutting	1	10
Product Costing	1	25
Risk Management	1	13
Root Cause Analysis	1	30
SMAW on Carbon Steel Plates	3	52
SMAW on BI Pipes	1	8
Smithery	1	13
TIG Welding on Carbon Steel Plates	2	21
<b>Total:</b>	<b>74</b>	<b>2107</b>

### Highlights of Packaged Training Programs

Our line-up of training programs also cater to the private companies' human resource development requirements. These companies are engaged in manufacturing, services and trading. The Center eagerly promotes related technologies, either conventional or contemporary, through designing training programs suitable to their needs.



Engr. Reynaldo L. Dela Cruz Jr. briefs Air Liquide Philippines participants on equipment to be used before the hands-on activity for GMAW & GTAW Processes Seminar/workshop conducted July 1 – 4, 2014.



Air Liquide Philippines participants perform hands-on activity for GMAW & GTAW Processes Seminar/workshop .

## Canon Business Machines Philippines, Inc.



Engr. Nelson L. Tumibay lectures on the physical properties of metal for Canon Business Machines Philippines, Inc. participants (left) for The Basics of Die Design & Fabrication and The Fundamentals of Pressworking Seminar (2 Batches).



Engr. Romanico F. Salido acts as resource person for Canon Business Machines Philippines, Inc. training participants.



Mr. Ernesto S. Sambo introduces the Vacuum Heat Treatment Facility with Canon Business Machines Philippines, Inc. participants.

## Philippine Auto Components



Dr. Dominic S. Guevarra lectures on Plastic Injection Molding Machine Programming & Operations with the Philippine Auto Components participants, February 3-7, 2014.



## Procter & Gamble Philippines



Procter and Gamble Philippines, Inc. participants perform practice welding and pose with their resource speaker during the TIG Welding Seminar/workshop conducted March 17 – 21, 2014 (B1).

### Southern Luzon State University (B1)



Students from the Southern Luzon State University (B1) perform assigned activity during the practical training on Machine Shop Operations (Conventional Milling & Grinding) conducted in August 2014.



Engr. Edilbert M. Dela Peña lectures to students from Southern Luzon State University (B1) on Machine Shop Operations (Conventional Milling & Grinding) conducted on August 11-13, 2014.

### Southern Luzon State University (B1)



Southern Luzon State University (B2) students perform hands-on and housekeeping activities on Machine Shop Operations (Conventional Milling & Grinding) conducted on August 13-15, 2014.

### Western Palawan University (2 Batches)



Western Palawan University (B2) students perform hands-on Machine Shop Operations & General Welding Processes.



Engr. Wilfredo R. Lim lectures to Western Palawan University students (B1) on Machine Shop Operations and General Welding Processes conducted on May 20-27, 2014.



Mr. Augusto S. Atanacio explains to Western Palawan University students (B2) topics on Machine Shop Operations and General Welding Processes conducted on May 20-27, 2014.



Engr. Jojit M. Velasco shares his expertise to Western Palawan University students (B2) on Machine Shop Operations and General Welding Processes conducted on May 20-27, 2014.

The MIRDC also conducts training in the regions as tabulated below:

### Regional Distribution of Training Programs Conducted

TRAINING PROGRAMS	NUMBER OF PROGRAMS IN THE REGIONS															TOTAL	
	NCR	CAR	I	II	III	IV	V	VI	VII	VIII	IX	X	XI	XII	CARAGA		ARMM
Metal Casting Technology																	0
Metalworking Technology	35	3	3	2	10	10	3				1	3		4		74	
Analysis & Testing	20				1	1										22	
Engineering, Prod. & Planning	5				1	1								2		9	
Management/Productivity Improvement	4				2											6	
Trainer's Training	1															1	
Others	13			2	1	1	1							1		19	
<b>TOTAL</b>	<b>78</b>	<b>3</b>	<b>3</b>	<b>0</b>	<b>4</b>	<b>15</b>	<b>1</b>	<b>12</b>	<b>4</b>	<b>0</b>	<b>0</b>	<b>1</b>	<b>3</b>	<b>0</b>	<b>7</b>	<b>0</b>	<b>131</b>

### Foretaste of regional training programs.



DOST-Calabarzon, Morong, Rizal – Electroplating Seminar conducted on July 15- August 13, 2014.

**Internal Quality Audit at DOST-NCR conducted on January 27 -29, 2014.**



Dr. Danilo N. Pilar explains certain topics during the seminar.



"Mock Audit" activity as part of Internal Quality Audit Seminar.



"Mock Audit" activity in the area of purchasing.



Participants report their "Mock Audit" findings during the Internal Quality Audit Seminar.



Taguig City University students attend the Information Seminar on ISO Awareness and Effective Presentation Skills conducted on December 15 & 16, 2014.



## Impact Assessment

The impact assessment is administered six months after the conduct of a training program to determine the impact/benefits gained by industries from the MIRDC's transfer of technology thru industrial training. Both private and public institutions are considered to be the respondents of this assessment except student-trainees who at-

tended information seminars or seminars that are part of their curriculum. The results will serve as a device for continual improvement in terms of technical knowledge and skills of the resource persons as well as in upgrading the curriculum design of the training programs.

Below is the tabulated result of the survey from January–December 2014. Two hundred forty four (244) firms responded during the survey.

IMPACT/BENEFITS	TOTAL	%
Enhanced Employees' KSA	615	55.96
Reduced Costs	39	3.55
Increased Production/Sales	33	3.00
Diversified Products	2	0.18
Others	80	7.28
Conformed to Standards	153	13.92
Transferred K & S	177	16.11
<b>Total:</b>	<b>1099</b>	<b>100.00</b>

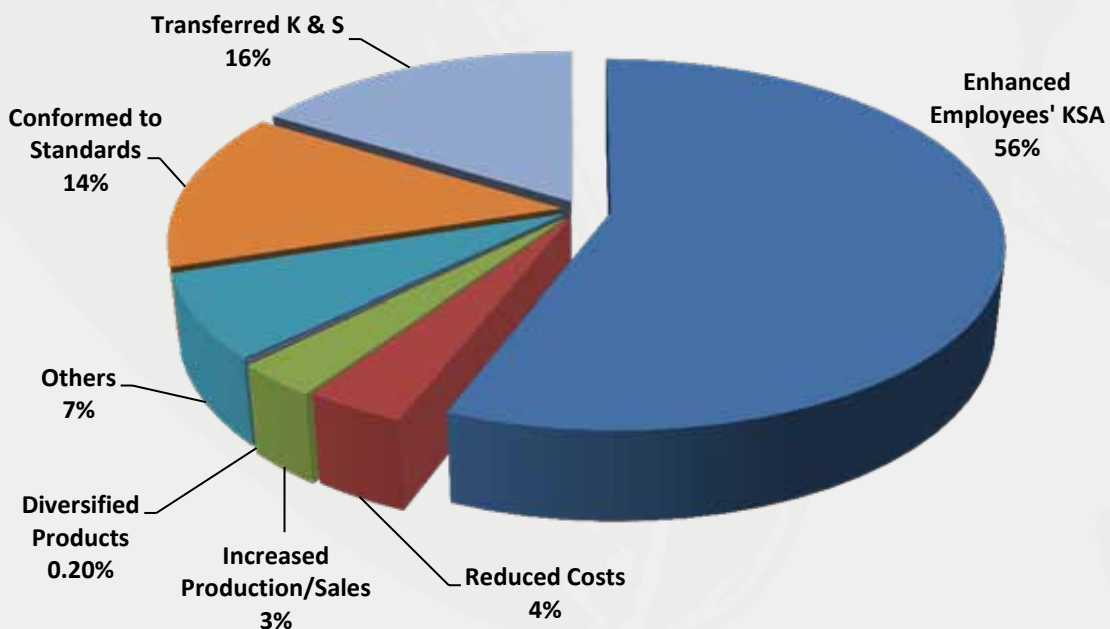

**Result of the Impact Assessment Survey of Training Programs Conducted in 2014.**

## CNC Machine Tool Programming and Operations Training Program

Part of the DOST-MIRDC's support to the Makinarya at Teknolohiya para sa Bayan (MakiBayan) initiative is the implementation of the Computer Numerical Control (CNC) Machine Tool Programming and Operations Training Program. This training program is the Center's parallel move to the Memorandum Circular No. 02 of the Department of Labor and Employment which declared CNC machining as a 'mission critical skill.'

Launched in 2012, the training program produced a total of 853 trainee-graduates by December 2014. The project has successfully exceeded the original target of 800 graduates, and is still presently being implemented. The DOST-MIRDC linked-up with various Partner Support Organizations (PSOs) at various stages of the project including the conduct of industry immersion. The PSOs include

industry associations (i.e., the Metalworking Industries Association of the Philippines, Inc. (MIAP), the Philippine Die and Mold Association, Inc. (PDMA) and the Aerospace Industries Association of the Philippines (AIAP)), TESDA Regional Training Centers, academic institutions, and metalworking firms. The DOST Regional Offices also provided much needed support in terms of recruitment and coordination of project-related activities. The DOST-MIRDC, through the CNC Training Program, is determined to meet the 'brain drain' challenge that the industry is currently facing. The new breed of CNC operators and programmers will spawn more empowered members of the M&E industries' workforce. With fresh CNC talents in charge of precision machining, the manufacturing industry will be more productive. This technology-based and innovation-driven initiative is the MIRDC's move toward making the Philippines a smarter 'Science Nation.'



CNC Hands-on Training



CNC Training Batch 4 held at the MIRDC



CNC Training Batch 1 held at La Union

**All the services and R&D initiatives of the Center are meant to boost the metals and engineering industries' growth and competitiveness. Thus, these activities need to be promoted in order to bring their benefits closer not just to the firms in the M&E, but to other stakeholders as well. The DOST-MIRDC's Technology Information and Promotion Section (TIPS) engaged in various activities that helped raise the public's awareness of the significance of the Center's initiatives. These were no easy tasks, but being able to contribute to the realization of the targets that we have set made all our endeavors meaningful and purpose-driven.**

The TIPS is involved in the delivery of the following support services which are integral to achieving Center-wide objectives:

**1. Development of Information Materials**

Through the collective efforts of the personnel from the TIPS, and the coordination with staff from other divisions, the production of several relevant information materials was made possible. The DOST-MIRDC has come to depend on the role of information dissemination to assist in the effective implementation of its projects and activities. The TIPS is proud to have successfully produced the 2013 Annual Report including the Jan-April, May-August, and September-December issues of the Trends and Events. Part of the TIPS' accomplishments with regard to information materials is the printing of Technology Brochures, the M&E Week Souvenir Program and the MIRDC 2015 Calendar. It is in 2014 that the MIRDC Management saw the timely revival of the Philippine Metals (PhilMets) publication, which served as the Center's official technical and economic news bulletin since its initial release in 1971. Its publication was discontinued in 1982. The TIPS was deeply involved in the production of the PhilMet's comeback issue. From here on, the TIPS will be an active participant in the preparation of the annual publication of the PhilMet which will add to the Center's tools for information sharing.

The TIPS collaborated with the staff of the R&D group to successfully come up with Technology Videos on the CNC Router and CNC Plasma Cutter. These materials will be presented to potential adopters and technology users as tools for viable technology transfer and commercialization.

**2. Participation in Exhibits**

The TIPS, through its participation in various exhibitions, brought the DOST-MIRDC technologies and services closer to where these can deliver the most benefits. Through the TIPS, the Center is able to reach out to the micro, small and medium enterprises, as well as to other government offices, local government units, and academic institutions including students.

In January, the TIPS participated in the Asia Pacific Drive Tourism Conference and Exhibition held at the Subic Bay Exhibition and Convention Center. Featured in the said event were technologies under the Advanced Transport Program of the MIRDC. This exhibition gave the Center an opportunity to promote the Centrally-powered Hybrid Electric Road Train (CRT) and the Automated Guideway Transit (AGT) System.

In July, the MIRDC's technologies were highlighted in the 2014 National Science and Technology Week (NSTW) that was held at the SMX Convention Center in Pasay City. For the Center's aerospace-related exhibit, the TIPS closely collaborated with the Aerospace





DOST Sec. Montejo (second from right) visits the MIRDC booth with (from left) Engr. Edgar I. Garcia, Director of DOST-TAPI, DOST Assistant Secretary Raymund E. Liboro, and DOST Assistant Secretary and MIRDC Officer-in-Charge Engr. Robert O. Dizon. Also in the picture (right) is Engr. Rex L. Bingbing, Director of the PhilMech.

Industries Association of the Philippines (AIAP), the Famous Secret Precision Machining, Inc. and the Moog Controls Corporation. The TIPS also featured other technologies such as the CRT, the Finite Element Analysis (FEA) Design Center, the Die and Mold Solution Center (DMSC), and the Surface Engineering Facilities.

The TIPS brought the same MIRDC technologies to the region in late July through its participation in the Visayas and Mindanao Metal Working, Machinery, Equipment, Hardware and Allied Industries Exhibition and Seminars (VizMMex) held in Lahug, Cebu City.

Then came the Regional Cluster S&T Fairs which are avenues for the MIRDC to reach out to the M&E industries in various locations of the country. In August, the TIPS brought the Center's technologies to Legazpi City, Albay. In September, the TIPS joined

the exhibit sponsored by the North Luzon Cluster held in Tuguegarao, Cagayan. During the same month, the TIPS also participated in the New Era University Science Fair held at the New Era Campus in Quezon City. The TIPS then participated in the Visayas Cluster S&T Fair held in Mandaue, Cebu in October, and in the final leg of the regional cluster S&T Fair held in SM Lanang, Davao City.

The participation of the MIRDC in exhibitions like the NSTW enhances the agency's technology transfer activities, as well as its other S&T initiatives. A lot of people viewed the exhibit and asked about the technologies being displayed. With the kind of interaction that the TIPS engaged in during the exhibitions, the MIRDC was able to make its presence felt among its clients, partners, and stakeholders.

### Outcome 3: Centerpiece



On proud display at the 2014 NSTW: servo valve actuators made by the Moog Controls Corp. (left) and the RP-S512 plane (right), a light sports aircraft locally assembled by the Famous Secret Precision Machining, Inc.



Exhibit viewers and students alike visit the MIRDC booth at the 2014 NSTW celebration.



Engr. Rodnel O. Tamayo, Chief of the Materials and Process Research Division (MPRD), talks about the AGT in ABS-CBN's Future Perfect TV Program.



Engr. Gharry M. Bathan talks about the Automatic Trash Rake in an interview conducted by a GMA7 reporter.



Engr. Rodnel O. Tamayo, Chief of the MPRD, shares updates about the Road Train project to RPN9.

### 3. Engagement with the Media

The MIRDC captured the attention of the media by means of its interesting and much talked-about technologies. Updates on projects like the AGT, the Computer Numerical Control (CNC) Machine Tool Programming and Operations Training Program, and the Road Train were featured in leading newspapers, radio stations, online, and top-rating TV shows. Aside from these, updates about other activities of the MIRDC were also uploaded online, giving interested parties, even those who are in far provinces, access to the latest happenings in the M&E industries.

### 4. Organization of and participation in Industry Dialogues/Info-seminars/Technology Launching

The DOST-MIRDC takes pride in nurturing beneficial partnerships with the industry which constantly remain strong through its open communications and joint activities. In 2014, the TIPS gave a significant contribution to make these partnerships even stronger by means of organizing and participating in Industry Dialogues.

In January, the TIPS was part of the Focus Group Discussion (FGD) on CNC Machine Tool Programming and Operations Training Program. Representatives from industry associations and firms in the M&E industries participated

in the FGD to provide valuable inputs regarding the training curriculum design. During the FGD, the industry commented on the remarkable accomplishments of the training program. Participants likewise gave insights on possible refinements so as to better mold the trainees to become the CNC talents that the industry needs.

In June, the TIPS was involved in the launching of the Surface Engineering Technology, as well as in the Info-seminar on TIG Welding, SMAW, CNC Milling, and Micro Cupola. Industry players, including the MSMEs, participated in the said activities to learn about the latest trends in these technologies. The TIPS later embarked on gathering information to assess the impact of



Participants undergo hands-on activity during the Oxyacetylene (left) and Shielded Metal Arc Welding Techno Demos.



Quezon City Mayor Herbert M. Bautista with DOST Sec. Mario G. Montejo, DOST Asec./MIRDC-OIC Robert O. Dizon, and MIRDC Deputy Director for R&D Engr. Jonathan Q. Puerto during the Automatic Trash Rake Facility launching.

these technologies to the participants' respective businesses.

Featured in a Technology Forum held during the 2014 NSTW were the Surface Engineering Technologies (Vacuum Heat Treatment and Anodizing), and the Finite Element Analysis (FEA) Design Center. The TIPS gathered together guests from the academe, the industry, and the government for this event. It was a well-attended event and all information about the said technologies were effectively disseminated.

In December, the TIPS was once again actively involved in the launching of the Automatic Trash Rake (ATR) held at the Quezon City Hall. The ATR is installed in a facility in Balingasa Creek along G. Araneta Ave., cor. Mauban St. in Quezon City. The launching activity aimed to present to the residents in the area a technology-based solution to flooding problems.

### 5. Conduct of Plant Tours

The Center is open to visitors who wish to learn more about the MIRDC's available facilities and state-of-the-art equipment for a more efficient delivery of its services to the industry. The TIPS successfully coordinated and conducted 67 plant tours in 2014.

### 6. Development of Industry Study

Through the TIPS, the Center conducted an industry study that focused on the Stamping Sector.

Valuable updated information have been consolidated and will soon be released to the industry. Further, the TIPS was able to generate and compile statistics on the import/export of stamping products, as well as other information relevant to the Stamping Sector.

### 7. Provision of Library Services

The MIRDC's Library is proud to have been able to serve a total of 776 researchers: 363 from the private sector; 380 from the academe; and 33 from the government. The Center's collection of materials and publications including books, scientific journals, among others,

provide researchers with useful information regarding the M&E industries.

In addition to all these, the TIPS spearheaded the creation of the 'MIRDC Showroom' which serves as an exhibit area/holding room for guests before the actual plant tour. This facility is intended to present to visitors the MIRDC 'in a nutshell.' The guests are given an overview of the technologies and services of various divisions of the Center.

The TIPS is determined to pursue the achievement of all its goals in order to keep in step with the MIRDC as it continuously finds ways of empowering the M&E industries. Perhaps to other people, hard work is just part of an ordinary day. For the TIPS, hard work is a culture that is both rewarding for the Center and its varied customers.



Excited students in line during plant tour

**M**IRDC transfers technologies through various modes such as technology demonstration and fora, establishment of facilities, lectures, participation to techno-fairs/exhibits, distribution of promotional materials, and press releases. It regularly provides technical services to existing technology partners through technical assistance, training and consultancy.

## Technical Consultancy

Various consultancy services to individuals and firms nationwide were provided to address their concerns on electroplating, heat treatment, welding, fabrication, smithery, metalcasting, metalworking processes, testing and analysis, calibration, coco-coir technology, muscovado processing/equipment, productivity improvement and quality management system, among others. These firms availed of the technical consultancy services with the aim of improving their product quality, increasing the volume of production, minimizing waste and increasing production efficiency. Two hundred seventy six (276) technical consultancy services to two hundred forty four (244) firms and individuals were conducted by the Center, mainly through its Technology Advisory and Business Development Section. The pie graph shows the breakdown of consultancy services provided by the Center in each region.

Technical Consultancies Conducted

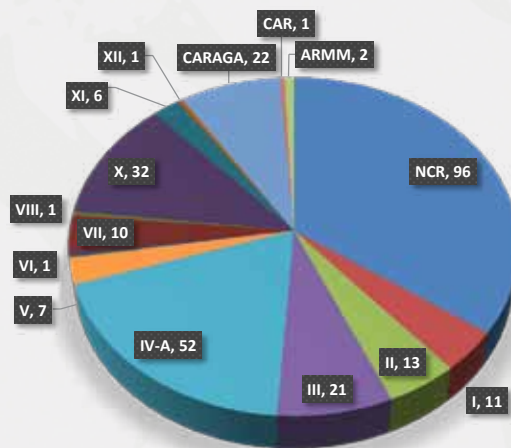

Engrs. Wilfredo R. Lim and Mervin B. Gorospe provide Consultancy on Investment Casting @ Bato Intl., Cebu

## Support to Various M&E Organizations

The MIRDC provides support to the M&E organizations through the provision of Secretariat or Office spaces. In 2014, the Aerospace Industries Association of the Philippines (AIAP) Secretariat Office became the latest addition. Other organizations include the Philippine Die and Mold Association (PDMA), the Mechatronics and Robotics Society of

the Philippines (MRSP) and the Philippine Welding Society (PWS).



Inauguration of the AIAP Secretariat Office.



Training facility provided for the PWS.

## Capacity Building for Competitiveness of the Metals and Engineering Industry Cluster (CAIMTEC) of CAR for the Localization of Industrial and High-Precision Technology Parts

The CAIMTEC project was aimed to raise the competency level of CAR-MSMEs to produce agro-industrial and high-precision technology parts conforming to international standards. The project which started in 2011 provided training and seminars and consultancy services to beneficiary firms. The project also developed the Job Order Information System (JOIS), a software program which will help firms in the acceptance and monitoring of job and inventory of manpower and production materials, and consequently, assist in the control and planning of their production activities. In 2014, the project provided seminar and coaching/consultancy on AS 9100c:2009 Aerospace Quality Management System. The JOIS software program was also presented for adoption to several firms in the Cordillera Administrative Region.

The Common Service Facility (CSF) for the CAIMTEC Cluster pushed through in partnership with Benguet State University (BSU). A Memorandum of Agreement between MIRDC - DOST-CAR – BSU was forged for the “DOST-BSU METALS (Metals and Engineering for Training and Local Industries Support).” The CSF will house two (2) machine tools, the Computer Numerical Controlled (CNC) milling and turning machines.



MIRDC team conducts ocular inspection of proposed Common Service Facility: BSU METALS @ Engineering Bldg., Benguet State University.



Presentation of JOIS @ DOST-CAR



**Assistance in the Establishment and Implementation of the Quality Management System for the DOST and Metals & Engineering Sector's Firms**

In their quest to improve quality and global competitiveness, M&E firms establish and maintain their Quality Management System based on ISO 9001:2008 standard. The MIRDC has assisted sev-

eral firms and DOST agencies in their endeavors. Among these are: RU Foundry and Machine Shop Corp. and the Philippine Nuclear Research Institute (PNRI) which received their ISO 9001:2008 Certification in April and December, respectively. K.E.A. Industrial Corporation, Supercast Foundry and Machinery Corp. (SFMC) and Product Equipment Resources Trading Inc. (PERT, Inc.), which were ben-

eficiaries of the Grant-In-Aid (GIA) project "Support to the Establishment and Implementation of the Quality Management System for the Metals & Engineering Sector's Beneficiary Firms," availed of the coaching and consultancy services in order to prepare them for their surveillance audits



*The Analysis and Testing Division's year 2014 can be summed up in one phrase: "sustaining a culture of success." The division is known to not just meet its targets, but to exceed its past remarkable performances. A culture of success can only be sustained by having dynamic people working hand in hand, banking on a foundation of values, expertise and experience. Gone are the years when ATD was only expected of delivering world-class scientific and technological (S&T) services to the public. Now, ATD, slowly but surely is shaping into a group capable of handling R&D projects that will greatly impact the lives of Filipinos. ATD continues to embrace the challenge of providing testing and metrology services to the metals, engineering and allied industries and at the same time actively involves itself in managing projects entrusted to it. In this annual report, the ATD would like to present the highlights of another breakthrough year.*

## Extraordinary Testing and Metrology Services

The division exceeds targets in regularity, and the year 2014 is no exception. Collectively, the division was able to serve 4,912 job orders, consisting of 19,200 samples. Those are equivalent to percent accomplishment rates of 136% and 137%, respectively. Below is the breakdown of jobs in terms of metrology and testing services.

Such accomplishment can be attributed to the continual maintenance of its laboratories' accreditation to ISO/IEC 17025:2005. This is proof that the services offered by the division are internationally accepted, and performed by competent laboratory personnel.

The year 2014 saw extraordinary jobs for the division in support to other government institutions. For the Instrumentation and Metrology Section (IMS), a major supplier of the National Nutrition Council of the Department of Health (DOH-NNC) entered a total of 20 calibration jobs consisting of 398 units of weighing scales. These scales will be distributed nationwide to be used by nutrition officers in determining the weight of the children. Data collected will in turn be used to determine correct health profiles of each child weighed.

The IMS also has been part of the initiative on the standardization of vehicular plates for the Land Transportation Office (LTO) and the business plates for the National Food Authority (NFA). The Metrology Laboratory served to ensure the quality of the plates in terms of dimensional measurements, against standards established by the said regulatory offices.

The MIRDC, through the Physical Laboratory Section (PLS), was chosen by the Atlantic Gulf & Pacific Company of Manila, Inc. (AG&P) as the sole testing laboratory for qualifying welding process to be used by their European customers. AG&P submit-

ted a total of 728 samples. Another NDT customer, Site Skills Training and FVJ Overseas Placement, Inc., submitted a total of 511 samples. The testing of the samples is done to check the quality of work of welders, and hence their competency, before sending them for overseas employment.

Another noteworthy job by PLS is testing the pressure vessel submitted by the Technical Education and Skills Development Authority (TESDA). The pressure vessel was an entry to the 10th ASEAN Skills Competition held in Vietnam. The pressure vessel has different welding positions to be subjected to hydrostatic and bend test. The said tests will determine the quality of the sample's weldment. The results of the tests are indicators if the process used to weld the vessel stands a chance of winning the skills competition.

The Corrosion Laboratory, on the other hand, has been significant with its Salt Spray Test wherein one of the highlights was when Bangko Sentral



The sample pressure vessel submitted by TESDA.

<b>MFO2 Technical Advisory Services</b>			
<b>No. of Services</b>	<b>Target</b>	<b>Actual</b>	<b>% Accomplishment</b>
Metrology	1,700	2,254	133 %
Testing	1,900	2,658	140 %
<b>No. of Samples</b>	<b>Target</b>	<b>Actual</b>	<b>% Accomplishment</b>
Metrology	8,000	11,760	147 %
Testing	6,000	7,440	124 %



IMS staff performs dimensional measurements of newly designed vehicle plates.



IMS checks the dimensional measurement of Business Plates submitted by NFA.

ng Pilipinas (BSP) availed of its services. BSP needs assistance in the conduct of a quality test and research for the new coins that will soon be released. This is in addition to other vital services like thickness and mass of coating determination for samples required to hold an International Commodity Clearance Marking (ICC).

Collectively, the Physico-Chemical and Corrosion laboratories adhere to their vision of global competitiveness with the new technology adopted. Their usual technical services are highlighted in what can be considered as one of the remarkable years for them. The laboratories analyzed and tested a total of 1,725 samples, comprised of G.I. wires and sheets, deformed steel and angle bars, rods and other materials coming from different institutions seeking certification as proof of compliance with the regulatory requirements of the Department of Trade and Industry-Bureau of Product Standards (DTI-BPS).

### CLS and PLS Facility and Equipment Upgrade

In relation to the Revitalization project, the year 2014 saw significant upgrade in the ATD's facility and equipment, especially the Physical Laboratories (PLS) and Chemical Laboratories Sections (CLS). "Advancing mechanisms in order to create new norms," is a mere representation to encapsulate the said upgrades.

Part of the advancement of the laboratories that was taken into account was the acquisition of different equipment for CLS. One example is the Couloscope that has the capability of determining the thickness of multiple element plated components. This will ensure if the corrosive-resistant trait of the products is comparable against established standards.

Another is the Cyclic Corrosion Chamber that has the same function with existing salt spray chambers wherein it determines the de-

gree of corrosiveness of a material under laboratory controlled conditions. But this instrument provides a "dry" option other than the usual "humid" condition. Setting the bar further, the Center's project also provided the section with new portable and benchtop coating thickness testers, weighing balances, and mandrel apparatus, among others.

In the case of PLS, one of the major equipment upgrades is the Micro hardness and Vickers hardness testers. Unlike the Center's old hardness testers, the new ones are interfaced to a computer and has an auto-calibration feature that minimizes operator errors. Case hardened, plated product and anodized coating can be measured accurately using the knoop indenter of the Micro hardness tester.



Couloscope



Cyclic Corrosion Chamber



CLS personnel performs testing using portable thickness of coating tester .



Micro Hardness Tester



Vickers Hardness Tester



Fatigue Tester

### Other equipment additions and upgrades

Description of Equipment	Application / Significance
Leeb Hardness Tester	One of the most commonly used tester to determine the hardness of automotive product. This hardness tester is versatile enough to cover a wide variety of automotive products and materials.
Surface Roughness Tester	Roughness measurement of automotive products is also important. This will ensure that the right amount of roughness is maintained to the product to ensure product conformance to design.
Magnetic Particle Test Bench	Used to detect surface and near subsurface defects in ferromagnetic materials. This machine is used in the automotive industry to ensure that the product is free from open to surface cracks which tends to reduce its useful life.

Many automotive products are exposed to repeated loading. Failure occurs in the product due to fatigue. Fatigue Tester will expose the automotive parts to cyclic loading. This will give manufacturers a guide on the fatigue properties of their products.

The other equipment additions and upgrades are summarized in the table above.

In addition to improvements in equipment, laboratories like the Instrumentation and Corrosion laboratories also underwent minor renovations including adjustments on room layouts. Such improvements were done to serve better the ATD's customers and accommodate their present needs.

Improvement in facility was manifested in CLS solely with the renovation of one of their two units, the Corrosion Laboratory, that commenced in December 2014 involving better layout for the testing and office areas. The Physico-Chemical Laboratory will undergo renovation by the first quarter of 2015.

### Participation in Technical Committees for Standards Formulation and Industry Support

The ATD, through its designated technical staff, provided support to the development of Philippine National Standard (PNS) through active participa-

tion in Technical Committees (TCs) on standards formulation of the Department of Energy (DOE), Philippine Accreditation Bureau (PAB), Bureau of Product Standards (BPS) and the Department of Transportation and Communication (DOTC).

The Technical committees participated in by the ATD technical personnel are the following:

- Jewellery (TC-54)
- Gas Cylinders (TC-6)
- Vehicle Harmonization and Standardization
- Metrology and Calibration

The Instrumentation and Metrology Section continuously provides assistance to other accredited metrology laboratories by acting as a reference laboratory during measurement audit activities. Calibration laboratories like Integrated Microelectronics, Inc.; Scientific Standards Services; Elohim Industrial Sales, Inc.; ATS Philippines Corporation; and Applied Calibration & Instrumentation System, Inc. gave their trust and confidence to ATD.

Most ATD personnel are also recognized by PAB as Technical Experts and Assessors in the fields of Metrology and Calibration, Mechanical Testing, and Chemical Testing laboratory accreditation.

### Support to R&D

To support the Center's research and project management capabilities, the ATD went out of its comfort zone to spearhead some R&D projects. These projects are designed to help advance our automotive and transport industries.



International Forum for Material Testing in Germany.

**A. Prototype Development of a Five-Coach Centrally Powered Hybrid Electric Road Train (CRT) and Light Hybrid Electric Road Train (LCRT)**

The diesel-electric hybrid powered road train features a regenerative braking system, fully-air conditioned cabins, extra wide automatic sliding doors, and modern-looking interior and exterior design. The five-coach prototype CRT and LCRT were designed with the aim of finding an alternative solution for mass transport and alleviating worsening traffic condition in Metro Manila and other urbanized places. The Filipino-made technology will also encourage a more environment-friendly mass transit system because of its lower carbon emissions.

From just being a design concept in mid-2013, the five-coach

prototype CRT was successfully fabricated during the first half of 2014, and then fully electro-mechanically integrated during the second half of 2014. The Prototype CRT will undergo performance testing at Clarkfield, Pampanga during the first Quarter of 2015, using approved hybrid train test protocols. The performance testing aims to verify its intended design to carry 65 persons per coach, travelling at a speed of as much as 50 kph.

On the other hand, the Prototype LCRT's fabrication is already finished. It is now undergoing electro-mechanical integration. The integration activities will be completed during the first quarter of 2015, after which a similar performance testing will follow. The LCRT, being the lighter version of the CRT, is designed to carry 40 passengers per coach.

**B. Revitalization of MIRDC's Testing Facility in Support of the Automotive Components and Parts Manufacturing Industry**

This project is one of the core projects under the Establishment of an Innovative Center for Motor Vehicle and Parts Development (iM-OVE) Program. The project aims to support the automotive industry by providing a state-of-the art testing facility. The new upgraded facility will also act as a venue to conduct R&D related activities of automotive parts and components manufacturers.



Fabrication of the CRT at Fil-Asia



The new locally-fabricated five-coach light hybrid electric road train (LCRT).

*In support to the Center's program and projects to strengthen the industry competitiveness of the M&E industries as well as to intensify the international linkages of the Center, the Planning and Management Division (PMD) shares equally significant accomplishments for 2014. Being at the forefront of establishing the Center's external networks and linkages, the group spearheaded the implementation of an international linkage agreement and the coordination for the conduct of study missions and benchmarking activities to different foreign RDIs. The assistance to the aerospace industries which was formalized through the signing of a Memorandum of Understanding (MOU) under the MakiBayan Program was also made possible through the efforts and initiatives extended by the group. On a more internal level, the PMD successfully carried out the conduct of the Strategic Planning which sets the direction of the Center for the next ten (10) years.*

## **A. Boosting the export competitiveness of the M&E partner companies**

In 2013, the Metals Industry Research and Development Center (MIRDC) was identified by the Centre for the Promotion of Imports from Developing Countries (CBI), an agency of the Netherlands Ministry of Foreign Affairs, as potential partner to implement the CBI's project on Metalworking Sector Asia in the Philippines. The project aims to improve the export potential of the country's metalworking sector by implementing an Export Coaching Program (ECP) that will support individual companies in their export activities to Europe. Aside from assistance to local metals and engineering firms, another area of cooperation in agreement with the CBI is the implementation of a development program for business support organizations such as DTI, MIRDC and concerned industry associations.

Early in 2014, the project proposal entitled, "Support to the Development of the Foreign Market of the Metals and Engineering Industries through Collaborative Efforts with the Metalwork-

ing Sector Asia Project – Philippines of the Center for the Promotion of Imports from Developing Countries, Ministry of Foreign Affairs of the Kingdom of the Netherlands (CBI)" also known as "Local CBI Project" emerged as a counterpart undertaking of the MIRDC and was approved for implementation with an initial funding of Php 3.5 million by DOST – PCIEERD. The project was headed by Ms. Mercedita G. Abutal, Chief of the Planning and Management Division (PMD), with the project team designated into three (3) significant functions: 1) Philexport Counterpart (technical audit team); 2) System/Software Development; and; 3) Project Monitoring Office – PMO (Administrative & Support). Major accomplishments were highlighted below:

### *1. Stakeholders Meeting*

Conducted on 12 February 2014, the stakeholders meeting gathered a total of thirty nine metals and engineering firms across different industry associations. The one-day event aimed to encourage companies to join the local CBI program. Interested companies were assessed using the identified criteria patterned after the CBI-Export Coaching Program (ECP) where direct assistance is extended to qualified companies with export capabilities (classified as Level 1 companies). Additional activities were likewise conducted to promote the project within the M&E sector.



A CBI consultant briefs participants to the stakeholders meeting.



Initial audit to partner companies.

## 2. Preliminary Visits and Initial Audits

Qualified applicant-companies were visited by the assigned technical audit teams and were endorsed for an initial audit which was conducted along with the CBI Consultant, Engr. Allan O. Gozon of Philexport-Cebu. A total of eleven companies were assessed during the preliminary visits to which ten (10) companies were recommend-

ed for initial audit. A harmonized export audit tool patterned after the CBI model was used by the auditors in assessing the export capabilities of partner companies. All auditors completed the three (3) - day Export Audit Training which is a pre-requisite course for technical auditors prior to the conduct of actual audit to companies.

## 3. Finalization of Level 2 Partner Companies

After thorough examination of the results of the preliminary visits and initial audits and following the recommendations of the CBI Consultant, the ten (10) qualified partner companies targeted for Year 1 were identified and finalized.

## 4. Development of Export Audit Software

The results of the preliminary visits and initial audits to qualified partner-companies were uploaded to the Audit Database System (ADS) - a system developed through the counterpart efforts of the Management Information Service (MIS) of the PMD. This is a database of assisted companies and the results of audits conducted. The database will be used in monitoring the companies' progress under the local CBI project.

## 5. Development of Philmet Website

The Philippine Metalworking (Philmet) Website was likewise developed to serve as the online directory of the metals and engineering industry and other related service providers in the country. It generally aims to promote the export capability of the local industry in

### Partner companies qualified for the Local CBI Project

Company	Company Address	Contact Person/Contact Details
1. Ambrose Industries, Inc.	16 Sooner Farm Compound, Barangay Timbao, Biñan, Laguna	CHARLON YU CHARMAN YU
2. JFS Precision Technology Corporation	11 <sup>TH</sup> St. , No. 12 Golden Mile Business Park – SEZ Carmona, Cavite 4116	DIOSDADO N. YANGO JR.
3. Optitech Machine Tools	Sooner Farm Compound, Brgy. Timbao, Biñan, Laguna	SHAUN RUSSEL ANG
4. Rytek International Marketing Corporation	38 Golden Road, Caloocan Industrial Division, Kaybiga, Caloocan	MELVIN DY
5. Fabricator Philippines, Inc.	35 Oliveros Drive, Balintawak, Quezon City	VINCENT LIM
6. VJF Precision Toolings Corp.	B1 L1-6 Reyvil Subd., Brgy. Magsaysay, San Pedro, Laguna	VERGILIO J. FARINAS
7. Samsotite Plastics, Inc.	158 San Vicente Street, San Pedro, Laguna	ALFRED ANG
8. Firstec Metallics, Inc.	Ampere St. corner West Road, LISP 1, 4025 Cabuyao, Laguna	RENE I. DELA CRUZ
9. OEM Thuyo Corporation	Caloocan City	JENNET CHEM-TAM
10. ERML Trading, Inc.	Tagaytay – Sta. Rosa, Purok 1, Putingkahoy, Silang, Cavite 4118	EDILBERTO RIVERA



Philmet website

the Philippines for subcontracting of products and services to prospective clients worldwide through online promotions and marketing. The development of the website, which was subcontracted to Forward Solutions, Inc., is the Center's response following the recommendation of the CBI to develop a single directory of all the metals and engineering companies in the country.

The user-friendly features of the website allows buyers and suppliers (M&E local companies) to register their business profile, interact online, update buyer requirements and supplier's products and more. It has an embedded Content Management System (CMS) for the MIRDC to administer and manage the content and data published in the Philmet website.

#### 6. Capability Building Activities (ECP)

As part of the Business Support Organization Development (BSOD) program of the CBI, three (3) of the members of the audit/technical team of the MIRDC participated in the Training on Export Marketing and Management held in The Hague, Netherlands on 10-14 March 2014 (1 pax) and 1-5 September 2014 (2 pax). The programme focused on the preparation of an effective Export Marketing Plan (EMP), EU market trends and developments and EU technical standards, norms and quality which were segmented into ten (10) brief topics to fit the five (5) – day program.

#### 7. Conduct of Training Programs and Consultancy Visits

Part of the major support of the project in the development of the export competitiveness of the ten (10) partner-companies is the conduct of training programs and consultancy visits wherein the beneficiaries are coached on the areas of product improvement, production operations, quality control, management, export management and market entry. The services of consultants and resource persons from other government agencies like the Philexport, the Department of Trade and Industry (DTI), the National

### Training Programs for the Local CBI Project

Title of Training Program	Sponsor/Resource Person	Date Conducted
1. Market Access / Market Requirements	MIRDC/Allan O. Gozon	9-11 July 2014
2. Basics of Exporting	DTI	22 August 2014
3. HS Code	DTI	18 September 2014
4. Strategic Planning	Wallace Business Forum	23-24 September 2014 & 2-3 October 2014
5. Export Marketing and Management	CBI/Peter Lichthart/Philexport/Other agencies	15-17 October 2014
6. Finalization of Export Marketing Plans (EMPs)	MIRDC/Allan O. Gozon	10-12 December 2014





Philippine representatives, Ms. Linda G. Rivera and Ms. Corazon S. Caparros, to the CBI's Export Marketing and Management Program (EXPRO) in The Hague, Netherlands in September 2014.

Competitiveness Council (NCC), the Department of Foreign Affairs (DFA) and the CBI, among others, were tapped.

### B. Capability upgrading through study missions

The MIRDC implemented the project entitled, "Capability Building for Science, Technology and Innovation (STI) towards a Self-Sustaining Research Development Institutes (RDIs) of the DOST" through a grant from PCIEERD which administers the Bases Conversion Development Authority (BCDA) funds. The project is a capability upgrading activity through study missions in selected countries. The objectives of the project are: to study the best practices and mechanisms of operations of similar RDIs on STI activities; to develop strong networks/linkages with S&T institutions; and to develop an operational framework including a mechanism to utilize income in transforming the MIRDC to world-class self-sustaining R&D institution.



Local CBI Project Leader, Ms. Mercedita G. Abutal, during a visit to the CBI booth at the ESEF Expo in Utrecht, Netherlands which is part of the EXPRO Program she attended in March 2014. With her are Mr. Staf Henderieckx, CBI Expert; Mr. Cor Dieleman, CBI Senior Program Manager; and Mr. Allan Gozon, PhilExport Consultant.



Participants of the 1<sup>st</sup> Local "EXPRO" Seminar with the Resource Speakers, Peter Lichthart and Allan Gozon held in MIRDC in October 2014.



Awarding of the Certificate of Appreciation to Mr. Peter Lichthart, CBI External Expert as one of the Resource Speakers during the 1<sup>st</sup> Local EXPRO Seminar held in MIRDC in October 2014.



Participants to the Local CBI Project's Seminare on "Overview on Basics of Exporting" conducted by DTI's Export and Trade Promotions Division on 22 August 2014.

## 1. South Korea

The MIRDC delegates, represented by Engr. Jonathan Q. Puerto, Deputy Executive Director for Research and Development and Ms. Mercedita G. Abutal, Chief of the PMD, along with other DOST delegates visited South Korea on 7-9 May 2014. Among the agencies visited were the Korea Institute of Science and Technology (KIST) and Korea Institute of Machinery & Materials (KIMM). Both agencies play a lead role in the national development of South Korea, thereby contributing to the betterment of the global community while enhancing Korea's status in the world.

Among the best practices observed in the country, which can also be adapted by the MIRDC, is the KISTORIUM of KIST which is a form of information dissemination through showcase of technologies and research activities in a museum setting.

## 2. Japan

After the visit to South Korea in May 2014, Dr. Agustin M. Fudolig, Deputy Director for Technical Services and Ms. Mercedita G. Abutal of PMD also visited Japan in June 2014 and were able to study the operations of six (6) Japanese agencies, namely: 1) National Institute of Advanced Industrial Science and Technology (AIST – Tsukuba); 2) Tokyo Metropolitan

Industrial Technology Research Institute – TIRI; 3) TIRI – Tama Techno Plaza; 4) Ministry of Education, Culture, Sports, Science and Technology – MEXT; 5) Japan Science and Technology Agency (JST); and 6) Japan Society for the Promotion of Science (JSPS).

The MIRDC delegates identified potential collaboration/exploratory activities with the visited agencies specially in the areas of experts exchange, short-term training of engineers on engine research/technology, surface coating and plasma technology and immersion of MIRDC personnel through application and enrolment to graduate courses offered by science and technology universities in Japan.



MIRDC Delegates with the officers of Korea Institute of Machinery & Materials (KIMM) during the Study Mission to Korea in May 2014.



Delegates from MIRDC with some officials from DOST-RDIs together with the officers of Japan's Ministry of Education, Culture, Sports, Science and Technology (MEXT) during the Study Mission to Japan in June 2014.



Asec. Robert O. Dizon delivering the Welcome Remarks during the Aerospace Industry Dialogue on 17 June 2014.



MOU signing between DOST Secretary Mario G. Montejo and AIAP President John T. Lee during the M&E MakiBayan 2014 Conference on 18 June 2014

### C. Full-pledged support for collaboration activities with the aerospace industries

#### Industry Dialogue

The Aerospace Industries Association of the Philippines (AIAP), in coordination with the MIRDC, organized a one-day industry dialogue entitled, “The Philippine Aerospace Industries: Overview and Prospects” held on 17 June 2014 at the MIRDC New Auditorium.

The event enabled the participants to get insights from current players in the Philippine aerospace industry, particularly from representatives of companies directly supplying to global aircraft manufacturers. The activity also enabled the participants to get acquainted with the AIAP and its members, and understand the challenges and issues faced by the industry. The dialogue also served as a venue to enhance cooperation between the private and public sectors.

One of the highlights of the dialogue is the presentation of the roadmap for the development of the aerospace industry, spearheaded by the AIAP, to encourage convergence of initiatives among potential partners and other stakeholders for the continued growth of the industry.

Equally significant were the launching and blessing of the new AIAP office housed within the industry wing of the MIRDC. These were conducted after the commencement of the industry dialogue.

#### MOU Signing

The Department of Science and Technology (DOST), represented by Secretary Mario G. Montejo, signed a Memorandum of Understanding (MOU) with the AIAP, represented by its President John T. Lee, to foster full cooperation of both organizations in the implementation, advocacy and promotion of the “Makinarya at Teknolohiya Para sa Bayan” (MAKIBAYAN) initiative to reach targeted milestones in energizing the growing aviation sector in the country.

The signing ceremony was highlighted during the celebration of the 2014 Metals and Engineering Conference last 18 June 2014 wherein the AIAP was welcomed by different industry associations as the newest addition to the pool of industry partners and players being assisted by the Center.

The DOST and the AIAP bind themselves into engaging in collaborative competitiveness enhancement projects which involve

capacity-building, improved access to technology, manpower development and R&D in the aerospace industry under the MAKIBAYAN initiative.

As envisioned, the program shall benefit the Philippines by addressing the technological, manpower and facilities needs of the industries, in partnership with the DOST.

### D. 2014 Metals and Engineering Week Celebration

The MIRDC religiously holds the Metals and Engineering Week every every third week of June by virtue and in compliance with Presidential Proclamation No. 144. This is in cognizant of the metals and engineering industries’ vital and significant role in the country’s economic growth and development, being an indispensable part in government and private infrastructure projects.

This year’s M&E Week highlights the celebration of the 2014 Metals and Engineering Conference on June 18, 2014 at the Platinum Auditorium, Prototyping Division, MIRDC. The theme, “MakiBayan 2014: Pushing Forward for Industry Competitiveness,” is a spin-off event to commemorate the second year implementation of

Prof. Hermes D. Bautista

## “The Compleat Foundryman”



Representatives of Partner Support Organizations (PSOs) of the CNC Training Project.



Prof. Hermes D. Bautista receives the Legacy Trophy from DOST Sec. Mario G. Montejo.

the MakiBayan initiative which was launched by the DOST in 2012.

A proud highlight of the celebration this year is the launching of the Die and Mold Solution Center (DMSC), which showcased the collaborative efforts of the MIRDC and the Philippine Die and Mold Association, Inc. (PDMA) to provide facilities, technology and manpower development interventions to enhance the competitiveness of the local tool and die sector. Also highlighted is the awarding of Plaque of Recognition to Partner Support Organizations (PSOs) of the CNC Ma-

chine Tool Programming and Operations Training Program under the project entitled, “Human Resource Intervention for Sustainable Growth and Competitiveness of the Metals and Engineering Sector: Development and Implementation of Appropriate Training Curriculum Design for CNC Machine Tool Programming and Operations.”

The activity would not be extra special without the traditional awarding of the 2014 Legacy Trophy. This year, the award was given to Prof. John Hermes D. Bautista of the Philippine Metalcasting Asso-

ciation, Inc. for his valuable contribution to the M&E industries. Tagged as “The Compleat Foundryman,” the MIRDC acknowledges all the efforts and hardworks of Prof. Bautista that have helped the MIRDC attain its mission and vision through the years.

### E. 2014 MIRDC Strategic Planning

As a significant response of the Center to the intensified commitment of the academe, the public and private partners and industry associations to its programs/projects/activities, the MIRDC initiated a strategic planning exercise to improve operations, set directions and priorities and to ensure that employees are working toward the attainment of the common goals of the Center.

A regular top-level activity, the strategic planning is conducted every five (5) years to revisit the strategic plans and programs of the MIRDC and to assess their alignment to the priorities and agenda of the current administration.

The planning process started with a four (4)-day in-house course on Strategic Planning conducted by the Wallace Business Forum on 23-24 September and 2-3 October 2014. On 22 & 28 October 2014, the management convened again for the SWOT Analysis, Formulation of Strategies and Review of the Vision, Mission, Objectives and Core Values. The finalization of the draft strategic plans took place on 6-7 November 2014 at Phinma Training Center in Tagaytay City.

The finalized strategic priorities will be disseminated during the 2015 Deployment of Plans and Programs for reference and information of all employees.



MIRDC top management and other officers pose during the Strategic Planning in Tagaytay City.

**T**he importance of the human resource and its management is a responsibility that needs constant attention and continual improvement. Through its interventions and initiatives, the Finance and Administrative Division plays a critical role in the successful implementation of programs, projects and activities of the MIRDC.

The FADs performance in the year 2014 is a critical factor to the harmonious and cooperative atmosphere characteristic of the MIRDC. FAD supervises hiring of new personnel and makes sure that there is an appropriate match between vacant position and employee capability. It encourages career advancement of employees by means of providing assistance in scholarship applications and local and foreign trainings. It oversees the provision of effective infrastructure. The FAD also supports all divisions and project teams, most especially with finance-related matters. Most importantly, the FAD is behind the organization of events such as the annual team building, Christmas Party, employees' day – to ensure the well-rounded development of the employees who make all the Center's successes possible.

## Personnel Strength

The Finance and Administrative Division (FAD), through its Administrative and General Services Section (AGSS), has sustained a total workforce of 202 from the total 226 plantilla positions by the end of calendar year 2014. Despite personnel movement brought about by transfers, promotion and

separations from government service, FAD-AGSS was able to fill-up 23 vacant positions comprised of 13 promoted staff, eight (8) new employees and two (2) transferees from other government offices.

Accordingly, the Metals Industry Research and Development Center congratulates and welcomes the following personnel:

## New Employees



Christian Glenn S. Ligon  
Senior Science Research Specialist  
Analysis and Testing Division



Morris D. Pioquinto  
Science Research Specialist II  
Analysis and Testing Division



Hazel Marie T. Murcilla  
Planning Officer II  
Planning & Management Division



Didier B. Sibal  
Planning Officer I  
Planning & Management Division



Marita Natividad T. De Lumen  
Draftsman II  
Prototyping Division



Maria Alicia B. Cabral  
Administrative Officer II  
Finance and Administrative Division



Genevieve M. Barsales  
Administrative Assistant I  
Prototyping Division  
(Detailed at the Office of the Deputy  
Executive Director for Technical  
Services)



Glen T. Dabela  
Administrative Aide III  
Finance and Administrative Division

## Transferees



Ms. Aurea T. Motas  
Chief Administrative Officer  
Finance and Administrative Division  
(Transferee from the DOST Central  
Office)



Ma. Rodessa Grace A. Mercado  
Administrative Officer I  
Technology Diffusion Division  
(Transferee from the Dangerous Drugs  
Board)

## Promoted Employees



Engr. Fred P. Liza  
Chief Science Research Specialist  
Prototyping Division



Engr. Rodnel O. Tamayo  
Chief Science Research Specialist  
Materials & Process Research Division



Osric Primo Bern A. Quibot  
Senior Science Research Specialist  
Technology Diffusion Division



Ervie B. Erispe  
Administrative Officer V  
Finance and Administrative Division



Ma. Elena G. Gurimbao  
Training Specialist III  
Technology Diffusion Division



Christian M. Ibañez  
Science Research Specialist II  
Analysis and Testing Division



Millet A. Mangunay  
Administrative Officer IV  
Finance and Administrative Division



Concesa T. Cortez  
Training Specialist II  
Technology Diffusion Division



Marlene R. Rafanan  
Administrative Officer IV  
Finance and Administrative Division



Ligaya M. Rubis  
Administrative Officer IV  
Finance and Administrative Division



Simplicio N. Morla Jr.  
Metals Technologist IV  
Prototyping Division



Katherine T. Llanto  
Administrative Officer III  
Finance and Administrative Division



Jaquelin J. Agonoy  
Training Specialist I  
Technology Diffusion Division

## Career and Personnel Enrichment

### Local Training Programs:

The Staff Development Unit (SDU) facilitated the processing and implementation of 57 local training programs out of a target of 47 programs.

The objective of the SDU is to implement 90% of the identified training programs based on its 2014 Human Resource Development Plan (HRDP). The SDU surpassed this target and was able to deliver a 121.27% achievement. The contributors in the attainment of the SDU's functional objective

HRDP 2014 Program Classification Distribution (%)

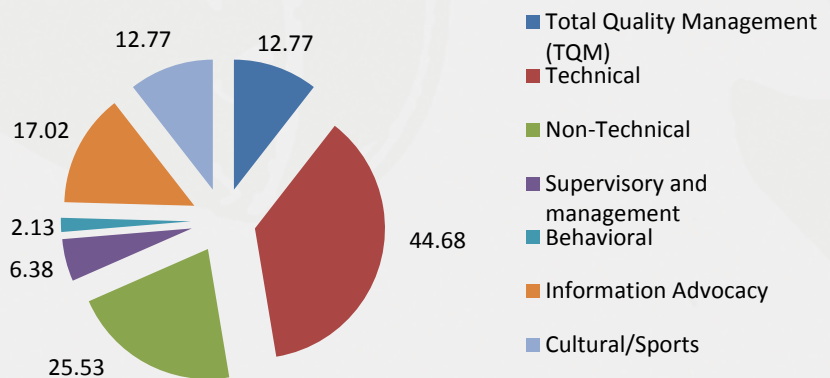

came from the different divisions through the extension of their technical support in the conduct of internal training programs.

Furthermore, the provision of slots for internal participants in the MIRDC's public-run training programs also form part of the support mechanism utilized by the FAD-AGSS. The Technology Diffusion Division, through its Industrial Training Section, provided a total of thirty two (32) slots for internal participants in its twelve (12) public-run training programs in the areas of Analysis and Testing, Metalworking, Engineering, Production & Planning and Quality Management Systems.

#### *Foreign Training Programs:*

The twenty three (23) foreign travels documented and processed by the SDU for the year was made possible through the nine (9) on-going projects under the MIRDC GIA Fund and the public-private sector partnership scheme. Private and public counterparts of these projects were MESCO Corp, Vector Data, Inc., Phil Data Business Systems, Inc. , Nicklaus Machinery Corp., Levin Int'l. Corp., NDT Instruments of Singapore, Zwick GmbH & Co. , VG Roxas Co., Inc., Atlas Material Testing Tech LLC, and the Ministry of Foreign Affairs of the Kingdom of the Netherlands.

Recipients of these international training programs are selected project leaders and members of the various technical projects handled by the different divisions like the Analysis and Testing Division, the Prototyping Division, the Materials and Process Research Division, and the Planning and Management Division. Listed below are the project titles involved in facilitating the foreign trainings held in Japan, China, Korea, Singapore, Vietnam, Malaysia, India, USA, Italy and the Netherlands:

- Development of Fluidized Bed Dryer for Production of Stabilized Brown Rice
- Establishment of a Die & Mold Solution Center in Support of the Components and Parts Manufacturing Industry;
- Support Program for the Productivity and Competitiveness of the Metals Engineering Industry;
- Revitalization of MIRDC's Testing Facility in Support of the Automotive Components and Parts Manufacturing Sector;
- Capability Building for Science, Technology & Innovation Towards Self-Sustaining RDIs of the DOST;

- Support to the Development of the Foreign Market of the Metals Engineering Through Collaborative Efforts with the Metalworking Asia Project-Phils. of the Center for the Promotion of Imports from Developing Countries, Ministry of Foreign Affairs of the Kingdom of the Netherlands;
- Design & Development of Local Microwave Vacuum Dryer;
- Development of Prototype Trainset; and
- Development of 12-Horsepower Single Cylinder Diesel Engine

Another international linkage activity undertaken by the Center was the participation of two (2) MIRDC personnel as the Philippine Representatives in the 4<sup>th</sup> East Asia Symposium on Technology of Welding and Joining held on October 21-26, 2014 in Xi'an China . Engr. Isidro D. Millo of the Prototyping Division and Engr. Reynaldo L. dela Cruz, Jr. of the Technology Diffusion Division, who are active members of the Philippine Welding Society, were extended with an invitation by the Chinese Mechanical Engineering Society (CMES) and the China Welding Society (CWS) to attend the event as delegates of the Society.

#### **Scholarship Program**

As part of the personnel career enrichment program for government employees, the DOST HRDP opened its doors to employees who are interested to avail of local and foreign scholarship programs. Through this scheme, the MIRDC employees were able to avail two (2) local and one (1) foreign Graduate Degree entitlements for the year. (see Scholarship Program Grantees Table.)

The FAD-AGSS recognizes the completion of Engr. Paul Danniell P. Aquino's Master of Science in Electrical Engineering at the Mapua Institute of Technology last October 22, 2014.

#### **2014 Women's Month Celebration**

The Philippine Commission on Women, in cooperation with the members of the GAD Focal Point System, spearheaded the Women's Month Celebration on March 24, 2014 with the theme "Juana, Ang Tatag mo ay Tatag Natin sa Pagbangon at Pag-sulong." This was organized to pay tribute to the strong and resilient "Juanas" who brought inspiring changes in the country. The event also recognizes the role of women in the rehabilitation process and their over-all contributions to progress.



ATD in winning the Best Costume Award – (Hawaiian Beach Costume)



FAD-AGSS salu-salo together in their very own bahay-kubo.



Osric Primo Bern Quibot of the TDD-TABDS won the crown as the MIRDC 2014 SEREYNA.



Engr. Pablo Q. Acuin of MPRD and Karl Andrew S. Chavez of ATD as contenders of the MIRDC Sereyna coveted crown.

### Scholarship Program Grantees

Name of Personnel	Division	Degree	University
1. Allan J. Limson 2. Gharry M. Bathan	PD PD	Master of Science in Mechanical Engineering (DOST HRDP Fund)	TUP Manila 2014-2016
3. Zalda R. Gayahan	TDD	Master in Technology Management (DOST HRDP Fund)	UP Diliman, QC 2014-2016
4. Osric Primo Bern A. Quibot	TDD	Masteral Degree on International Development (Japanese Grant Aid for HRD Scholarship Fund)	Nagoya University, JAPAN Aug. 2014- Oct. 2016

To partake in this event, the Center mobilized fifty five (55) MIRDC personnel to join the various activities set forth by the GAD Committee. Among these were the Juana Walk – A Walk for a Cause, Juana Talk, Juana Dance and Beauty Session by Slimmer’s World, Free Hair Cut and Make-up by Ricky Reyes Learning Institute, Trade Fair and the Women’s Symbol Formation.

#### MIRDC Goes to Sea

As part of the “theme celebration” series of the MIRDC, the FAD-AGSS conducted the 2014 Teambuilding entitled “MIRDC Goes to Sea”

at the Monte Vista Resort, Sariaya, Quezon on April 24-25, 2014. To reinforce the spirit of sea adventure among the employees, each division was provided with a “kubo” along the shoreline as their get-together area. Added to this, the teambuilding committee injected beach-inspired group dynamic activities and inter-division contests. One of its much-awaited event is the MIRDC Sereyna pageant participated in by Karl Andrew S. Chavez of ATD, Galicano M. Enerlan of FAD, Pablo Q. Acuin of MPRD, Emerito V. Banal of PD and Osric Primo Bern A. Quibot of TDD.



### MIRDC Masquerade Ball 2014

The MIRDC celebrated its 48<sup>th</sup> Anniversary on June 20, 2014 with the theme "MIRDC Masquerade Ball 2014: Celebrating Today's Success...A Glimpse of the Future." All male and female employees and guests came at the Gold Auditorium donned in their best semi-formal attire and color coded masquerade ball mask ranging from red, blue, black, green, orange and fuchsia. The crowd enjoyed the dance presentation of the different divisions as well as the raffle of prizes. A total of 187 employees and 111 contract of service and guests graced the event.



### MIRDC FUNtasy Christmas Ball 2014

The culmination of activities for the year 2014 was the celebration of the MIRDC FUNtasy Christmas Ball 2014 on December 18, 2014. With the objective of promoting camaraderie among MIRDC's Top Management and the rank and file staff, the FAD-AGSS culled the idea of the division group presentation #followtheleader #showmopegmo. This is a first-time opportunity for the leaders of the Center to share their talents among their staff through a dance or song number. Surprisingly, even the TOP ranks led by Asec. Robert O. Dizon, graciously joined the festive mood by showcasing their own peg #SHOWTIMEdancemoves creating a more fun and relaxed atmosphere among the crowd. To complete the merriment, all divisions have dressed-up in their funtasy costumes from Walt Disney characters to super heroes and fantasy movie characters. The FAD-AGSS, in their Harry Potter attire, won the Best in Funtasy Costume Award.



The PRAISE Committee took the opportunity to present and recognize the awardees for the Loyalty, Performance Excellence and Special Awards during the event. Once again, the MIRDC expresses pride in its human capital, for the number of years in service and outstanding performance.

LOYALTY AWARDS 2013	
No. of Years	Awardee
Forty (40) Years	• Wilfredo M. Ramilo
Thirty Five (35) Years	• Rodolfo C. Serquiña
	• Natalio L. Rodriguez
	• Marcela R. Cagalingan
Thirty (30) Years	• Serafin G. Aguilar
	• Generoso V. Toque
	• Reynaldo M. Loreto, Jr.
Twenty Five (25) Years	• Alfredo Z. Panganiban
	• Edwin S. Jucutan
	• Ma. Elena G. Gurimbao
	• Corazon S. Caparros
	• Mildred J. Viernes
	• Judy A. Belga
	• Agustin M. Fudolig
Twenty (20) Years	• Ma. Girlie M. Millo
	• Arnold R. Habana
	• Eldina B. Pinca
	• Ligaya M. Rubis
	• Isidro D. Millo

Special Award 2013		
Category	Awardee	Division
Best Organizational Unit	Industrial Training Section	TDD
CORE Value Award	Restituto Felipe R. Gabuya	PMD
	Ervie B. Erispe	FAD
	Reynaldo M. Loreto, Jr.	TDD
	Melchor A. Gamilla	MPRD
	Samuel A. Ysit	ATD

<b>Performance Excellence Award</b>		
<b>No. of Years</b>	<b>Awardee</b>	<b>Division</b>
One (1) Year 2013	Florale G. Gamo	OED
	Katherine T. Llanto	OED
	Evelyn D. Inventor	FAD
	Zenaida L. Jumilla	FAD
	Virgilio P. Lim	MPRD
	Benson A. Ragasa	MPRD
	Rodolfo C. Serquiña	PD
	Ronaldo L. Agustin	TDD
	Luisito N. Alcantara	ATD
	Christine P. Avelino	ATD
	Myro Jon M. Barona	ATD
	Rommel N. Coroña	ATD
	Eduardo V. Diasanta, Jr.	ATD
	Lito I. Dimaculangan	ATD
	Angelito N. Pilar	ATD
	Mary Joy C. Revilla	ATD
	Samuel A. Ysit	ATD
	Jyrwen A. Ayao	MPRD
Two (2) Years 2012-2013	Lemuel N. Apusaga	MPRD
	Melchor A. Gamilla	MPRD
	Efren A. Andal	PD
	Virgilio H. Macanip	PD
	Ramon M. Martin	PD
	Simplicio N. Morla, Jr.	PD
	Zalda R. Gayahan	TDD
	Reynaldo M. Loreto, Jr.	TDD
	Marlyn U. Ramones	TDD
	Lina B. Afable	TDD
	Ronilo C. Sanchez	ATD
	Three (3) Years 2011-2013	Noli P. Alvior
Francisco M. Marasigan		PD
Rosalinda M. Cruz		TDD
Ma. Elena G. Gurimbao		TDD
Teresita C. Viloso		TDD
Louren Joy G. Asmando		ATD
Four (4) Years 2010-2013	Celso L. Aguisanda	MPRD
	Romeo C. Bermudez	MPRD
	Gabriel D. Galotia	MPRD
	Juanito G. Mallari	MPRD
	Joseph A. Romero	MPRD
	Ariel R. Sernal	MPRD
Five (5) Years 2009-2013	Marcela R. Cagalingan	FAD
	Jocelyn F. Dime	TDD
	Agnes I. Josef	TDD
	Marlene R. Rafanan	TDD
	Ligaya M. Rubis	TDD
	Luis C. Forbes	ATD



## DOST Special Field Day 2014

In compliance with Presidential Proclamation No. 958 "Declaring the Year 2005 to 2015 as the Decade of Healthy Lifestyle" and the Civil Service Commission (CSC) Memorandum Circular No. 06 adopting the National Policy of Sports for all Government Agencies, the Department of Science and Technology organized a special field Day among its attached agencies.

The DOST Special Field Day for Physical Fitness and Healthy Lifestyle Activities dubbed as "DOST-Wide Theme Building" held its opening ceremony at the Philippine Science High School Grounds on October 24, 2014. The program of activities included Best Muse Competition in a Mardi Gras costume, Theme Games of group dynamics, All Star Basketball and Volleyball Games and the Mass Zumba led by the DOST Secretary Mario G. Montejo together with the repre-

sentatives from other DOST agencies.

One of the major highlights of the event was the Parade of Muses of the different DOST agencies in their Mardi Gras costumes. MIRDC's best bet in the competition for Best Muse was Ms. Charmine C. Ferraris, a contract of service personnel, who paraded in a gold southern ethnic princess-inspired dress accentuated by a ray-of-sun head dress that completed her elegant Mardi Gras look.



MIRDC Representative, Ms. Charmine C. Ferraris in her Gold Ethnic Princess Mardi Gras costume designed by her personal handler Sephie Dayag.



MIRDC's Muse showcases her ray-of-sun head piece, a product of MIRDC's CNC Laser and CNC Router Machines created through the craftsmanship of Virgilo Y. Macanip Jr. and Renann G. Baldovino.



Sec. Montejo leads the Mass Zumba.



Asec. Dizon, together with Dr. Fudolig and Engr. Puerto, leads the parade of MIRDC players and Muse along the PSHS grounds.



Ms. Jelly N. Ortiz, together with Dolly Marie T. Borlado, helps mobilize the MIRDC players for the parade.

## Plant Tour of MIRDC Facilities

Last November 11, 2014, the Staff Development Unit in cooperation with the ATD, PD and MPRD conducted a Plant Tour of MIRDC Facilities among its employees in order to create an awareness on the various projects handled by the Center, focus-

ing on the Center's facilities, machines and equipment.

The tour covered the laboratory facilities of the Nondestructive Testing and Mechanical Testing, Surface Engineering, Die and Mold Solution Center as well as the Automated Guide-Way Transit.



Engr. Fred P. Liza, Chief of PD, introduces the men behind the machines (Die and Mold Solution Center).



Employees get a glimpse of the MIRDC's High End Machines.



Engr. Joey G. Pangilinan explains the use of the Surface Engineering Facility.



Employees on their way to the Electroplating Laboratory.



Prepping up employees before boarding the AGT.



Employees on their way up the AGT.



On-Board the AGT with Engr. Joey G. Pangilinan.



On-Board the AGT with Engr. Joey G. Pangilinan.



Employees pose with the AGT as background.



**Tribute**

Before the end of 2014, the FAD-AGSS processed a total of six (6) employee retirement benefits, four (4) of which came from the Administrative and General Services Section, one (1) from the Industrial Training Section and another one (1) from the Management Information System Unit.

In commemoration of their valuable years of service in the government service, the MIRDC awarded a Plaque of Recognition and a small token of appreciation to the following:

Name of Retiree	Effectivity Date	Years of Service
Danilo A. Cruz	January 1, 2014	43
Gloria SD. Erispe	March 1, 2014	38
Eugenio R. Mercado	June 2, 2014	42
Agnes I. Josef	June 30, 2014	36
Nicanor N. Rosairo	August 1, 2014	39
Judy A. Belga	October 3, 2014	25

2014 has been a year of fruitful projects, entailing disbursements from allotments and obligations. Being a government organization based on fiduciary capacity, resources are to be managed with utmost care. The Financial Management Section, comprising of the Accounting and Budget Units, exerted collective efforts to stay true to the mandate of handling the government funds entrusted to MIRDC hence, the financial figures presented is a truthful testament on how the Center has used the funds entrusted to it by the National Treasury.

To begin with, 2014 started with the receipt of the Notice of Cash Allocation and as per the Notes to the Financial Statements submitted, as shown in Table 1 and further illustrated in Figure 1.

The Trust Liabilities shown in Table 2 on page 75, comprises of the fund transferred by other government agencies given in trust for the center to utilize in the implementation of various projects.

Aside from the mentioned funds, the Center has the following allotments, obligations and bal-

ances, in CY 2014, which the Center has for its utilization: a total allotment of P660,942.00 to which it incurred obligations of P557,998.00 leaving an unexpended balance of P102,944.00.00 (see Table 3 and Figure 2). This is inclusive of CY 2013 continuing appropriations amounting to P121,493.00.

Being a government institution strongly adhering to the core values of Dynamism and empowerment by infusing vigor and enthusiasm, and deriving its collective success from the employees'

**Table 1 and Figure 1. Notice of Cash Allocation for CY 2014**

1. Regular Allotment	966,938,500.00
2. Accounts Payable	7,988,012.00
3. Trust Liabilities	103,077,432.61
<b>Total</b>	<b>1,078,003,944.61</b>

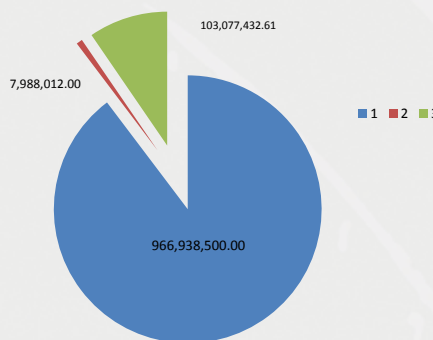

**Table 3. Breakdown of Appropriations for CY 2014 (in Millions)**

	1. Personal Services	2. Maintenance and Other Operating Expenses	3. Capital Outlay	4. Locally Funded
Allotments	136,280.00	126,755.00	24,403.00	373,504.00
Obligations	136,280.00	123,354.00	23,224.00	275,140.00
Balance	0.00	3,401.00	1,179.00	98,364.00

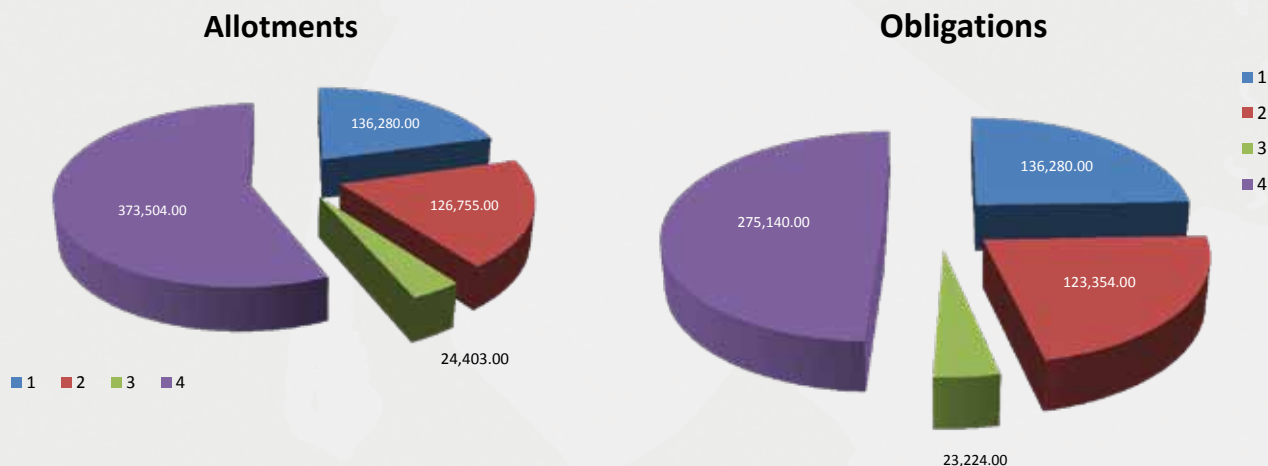

**Figure 2. Allotments received and Obligations made in 2014**



individual efforts and capabilities, the Center has under its belt the 2014 Income to boot. Even though the Center exists not for profit, but to provide the industry with professional management and technical expertise, it has, as testament to staying true to its mission, the Results of Operations from providing service to its clients (see Table 4). The figures indicate that we generated an income of P29,272,365.47 for the year 2014, 88% of which were gained from the delivery of its research and development and scientific and technological services and the rest were generated from rental of its facilities, interest and other miscellaneous income.

Although it has been told that success is measured by numbers, given the figures presented as such were indeed a result of each and every employee working on the clock nonstop just to provide the quality service to which the Philippine Government is mandated. The true success of the Center is truly its employees who, now more than ever, has continued to provide excellence in the fields of engineering, information exchange, quality control and testing of metal products, research and development and business economics advisory services. At the dawn of its golden year, may each and every cog and screw of this wondrous clock that is Metals Industry Research and Development Center, continue to be as vigorous and hardworking so that it will be known through the continuous support of the government, in addition to the already steady workforce of the center, that MIRDC will soon be on its way to become an internationally recognized institution, known for its quality services aforementioned.

**Table 2. Trust Liability: Grants in Aid (GIA) Projects**

PARTICULARS	AMOUNT
<b>To cover trust receipts representing financial assistance for the implementation of Grants-in-Aid (GIA) projects :</b>	
Technical Study for Value Adding of Philippine Iron Resources	177,143.44
Development of a Low-Cost and Locally Designed Meteorological Buoy	275,864.15
Human Resource Intervention for the Sustainable Growth and Competitiveness of the Metals and Engineering Sector: Development and Implementation of Appropriate Training Curriculum Design for CNC Machine Tool Programming and Operations	17,829,734.44
Development of Prototype Automated Guide-Way System	2,962,677.73
Phase II- Capability Upgrading of Micro Small and Medium Enterprises In the Metals & Allied Engineering Sector Through Technical & Management Trainings - DOST-NCR	13,531.67
Capacity Building for Competitiveness of the Metals and Engineering Industry Cluster (CAIMTEC) of CAR	2,574,770.59
Design and Development of Process Equipment for Food Processing Firms	1,641,549.69
Development of Vacuum Oil Quench Heat Treatment Furnace	5,304,219.47
Project 4: Design & Fabrication of Equipment for the Production of Local Cacao Products	1,645,390.44
Technoville Skills Upgrading Program: Upgrading the Welding Skills of Selected Residents of Bgy. Tanza, Navotas	66,530.00
Strengthening the Project Management and Engineering Design Services Office at DOST	7,118,689.00
Development of Handtractor Attachments to Harvester and Transplanter	3,692,749.68
Design and Development of Superheated Steam Treatment System for Stabilized Brown Rice	4,152,913.57
Development of Fluidized Bed Dryer for Production of Stabilized Brown Rice	4,459,141.22
Retrofitting of a Compact Rice Mill for Brown Rice Production	2,247,762.77
Roll-out of DOST-Developed Food Processing Equipment to the Regions	22,682,510.00
Development of Tent Systems for Emergency Applications	1,500,000.00
Study on the Viability of Deploying the Automated Guide Way Transit/Road Train Technologies in Baguio City	1,000,000.00
Establishment of Gear Making and Assembly Facility (Year 1 and 2)	16,538,128.00
Setting-up of One-Stop Shop Laboratory Services for Global Competitiveness (OneLab)	286,615.00
<b>TOTAL</b>	<b>96,139,921.25</b>
Amount covering Customer's Refunds and Other Trust Receipts	6,937,512.14
	<b>103,077,433.00</b>

**Table 4. Results of Operations**

Rent Income	3,550,012.42
Other Service Income	
Materials and Process Research	3,986,876.11
Prototyping Services	1,298,296.52
Analysis and Testing Services	17,665,479.54
Consultancy Services	97,683.54
Printing and Publication	8,224.51
Seminar Fees	2,664,119.23
Interest Income	1,673.60
<b>TOTAL INCOME</b>	<b>29,272,365.47</b>



**From left: Dr. Agustin M. Fudolig** (Deputy Executive Director for Technical Services), **Engr. Robert O. Dizon** (Asoc. DOST/OIC, MIRDC), **Engr. Jonathan Q. Puerto** (Deputy Executive Director for Research and Development), **Dr. Rio S. Pagtalunan** (Chief, Analysis and Testing Division), **Engr. Fred P. Liza** (Chief, Prototyping Division), **Dr. Danilo N. Pilar** (Chief, Technology Diffusion Division), **Ms. Aurea T. Motas** (Chief, Finance and Administrative Division), **Ms. Mercedita G. Abutal** (Chief, Planning and Management Division) and **Engr. Rodnel O. Tamayo** (Chief, Materials and Process Research Division).



# GOVERNING COUNCIL



**JIMMY T. CHAN**  
Metals Industry Sector



**RUDY B. CAÑA**  
Board of Investment



**MARCELO B. VILLANUEVA**  
Allied Industry Sector



**ROLANDO A. JAURIGUE**  
Engineering Industry Sector



**ROBERT O. DIZON**  
Assistant Secretary, DOST and OIC, MIRDC



**TEODORO S. SOLSOLOY**  
Department of Agriculture



**JUANCHO PABLO S. CALVEZ**  
(Representative of Leo L. Jasareno)  
Department of Environment and Natural Resources



**GERARDO P. MAGLALANG**  
Bureau of Products Standards



**BRENDA R. MENDOZA**  
National Economic & Development Authority

**MARIO G. MONTEJO**

DOST Secretary

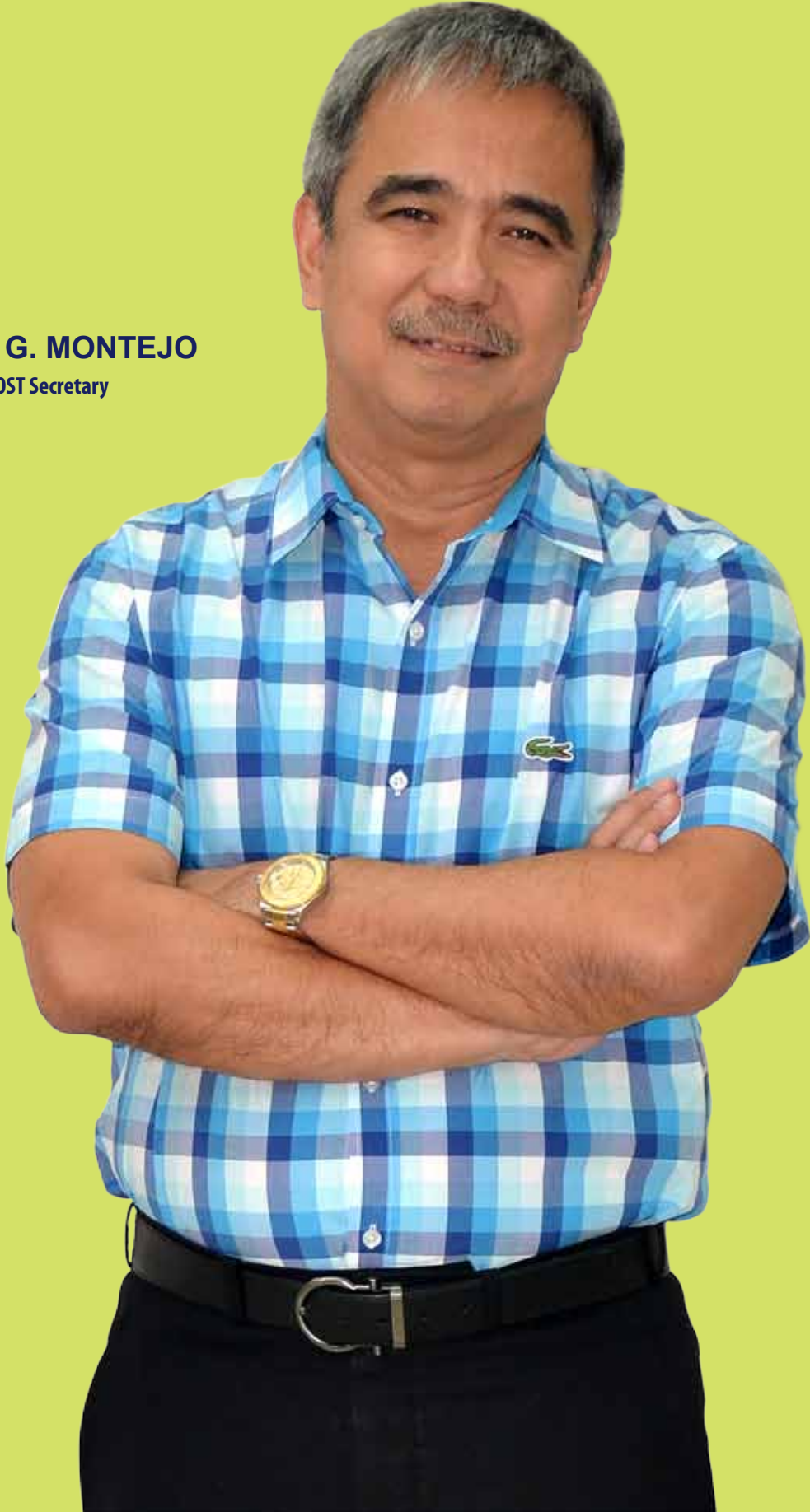

# LOCATION MAP & EXTENSION OFFICES

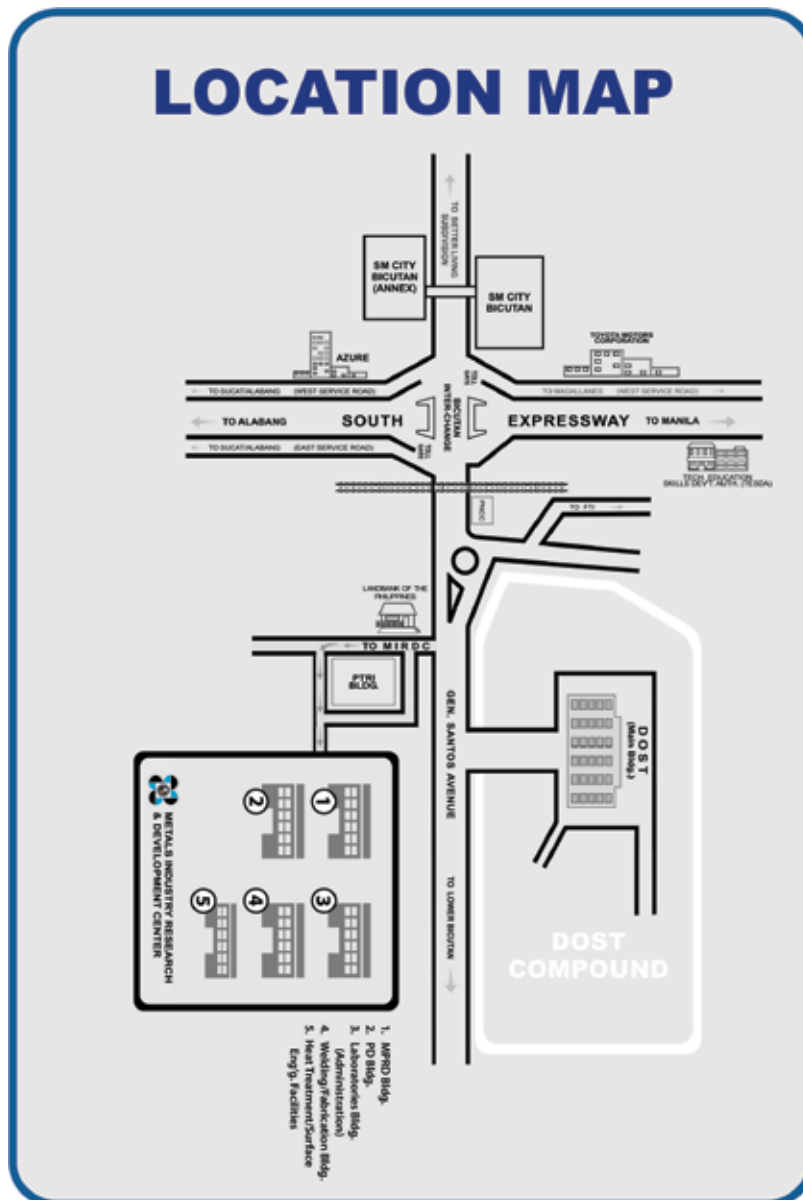

## REGION VI

DOST Regional Office No. 6  
 Magsaysay Village, La Paz, Iloilo City  
 Tel. No.: (033) 320-0908  
 Fax No.: (032) 320-0908  
 Contact Person: Engr. Felipe G. Pachoco

## REGION X

DOST Regional Office No. 10  
 J. R. Borja Memorial Hospital Compound  
 Carmen, Cagayan de Oro City 9000  
 P.O. Box 150  
 Tel. No.: (088) 858-3931 (Admin)  
 (088) 858-3932 (Director's Office)  
 (088) 858-3933 (Technical)  
 Contact Person: Engr. Roy C. Sagrado

# MIRDC ORGANIZATIONAL STRUCTURE

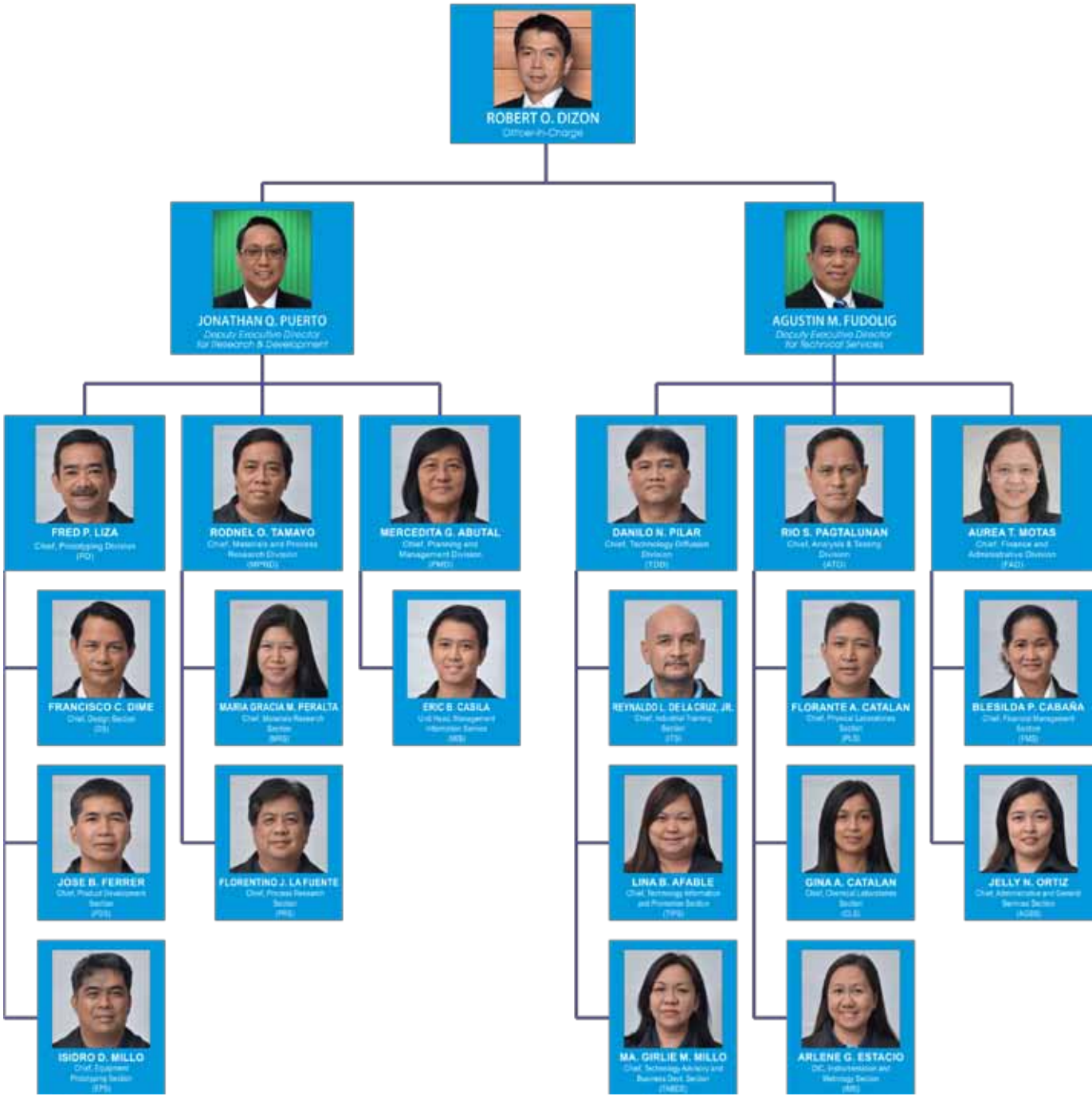

# MIRDC HYMN

## **Kaya Ko, Kaya Mo, Kaya Nating Lahat**

Tungkulin mo't tungkulin ko  
Paglingkuran lahat kayo  
Buong husay, buong ingat  
Sa lahat ng oras  
Gamit ang Agham at Teknolohiya  
Patuloy na manaliksik pa  
Handog twina, bagong kaalaman  
Industriyang metal mapayaman  
Kung kaya ko, ay kaya mo  
At kaya nating lahat  
Lahat ng bagay na mabigat  
Kung sama-sama'y mabubuhay  
Ang pag-unlad matutupad  
Kung matapat ang gaganap  
Ikaw, ako, tayong lahat  
Isusulong ang bukas

### Koro 1

Kaya ko, kaya mo, kaya nating lahat  
Industriya ay tutulungan, pribado o gobyerno man  
MIRDC ang Sentro na magbubuklod nito  
Ang tagumpay makakamit kung sama-sama tayo

### Instrumental

Tungkulin ay gagampanan, kakayahan ilalaan  
Tayo ay maglilingkod nang buong katapatan  
Gagawin nang mabilis, lahat sa tamang paraan  
At ating mararating tagumpay na inaasam

(Ulitin ang Koro 1)

### Koro 2 (a capella)

Kaya ko, kaya mo, kaya nating lahat  
Ating baya'y tutulungan, marating ang pag-unlad  
Tayo ay magtulungan upang ating marating  
Ang pag-unlad kung sama-sama'y kaya natin

(Ulitin ang Koro 1 at instrumental)

Kaya ko, kaya mo, kaya nating lahat



# *editorial board*



From left: Sheena S. Bedis, Daniel Paul P. Aquino, Celina D. Brual, Marlene R. Rafanan, Rodnel O. Tamayo, Fred P. Liza, Danilo N. Pilar (*Editor-in-Chief*), Ronald L. Agustin, Zalda R. Gayahan, Marlyn U. Ramones, and Lina B. Afafe.



**DEPARTMENT OF SCIENCE AND TECHNOLOGY  
METALS INDUSTRY RESEARCH AND DEVELOPMENT CENTER**

MIRDC Compound, Gen. Santos Avenue, Bicutan, Taguig City, 1631 Metro Manila  
P.O. Box 2449 Makati, 1229 Metro Manila, Philippines  
Telephone Nos.: (632) 837-0431 to 38 (connecting all departments)  
Fax Nos.: (632) 837-0613 and 837-0479  
Website: <http://www.mirdc.dost.gov.ph>  
E-mail: [mirdc@mirdc.dost.gov.ph](mailto:mirdc@mirdc.dost.gov.ph)